

Eidg. Institut für Reaktorforschung Würenlingen  
Schweiz

# The possibility of continuous in-core gaseous extraction of volatile fission products in a molten fuel reactor

M. Taube



Würenlingen, Mai 1974

The possibility of continuous in-core gaseous extraction  
of volatile fission products in a molten fuel reactor

M. Taube

May 1974

Abstract

A system of continuous gas purging of a reactor core for removal of volatile fission products from the molten chloride fuel is discussed and calculations based on a computer programme are shown. The results indicate:

- a) the precursors of the delayed neutrons nearly all remain
- b) iodine-131 in the steady-state core is reduced approx by a factor 1000
- c) caesium-137 concentration in the core decreases only by a factor 7, but the volatility is relatively low due to chloride
- d) caesium isotopes 135 and 133 can be separated from Cs-137 by a factor of which make easier the Cs-137 management
- e) xenon isotopes are extensively extracted

All this results in a significant improvement in the safety of this reactor type in the case of a core accident.

## 1. General Remarks

The aim of this paper is to discuss the possibility of decreasing the concentration of volatile fission products in the steady state core as a counter measure in the event of a core accident.

The design philosophy of a safe reactor is guided by the statements of the following type: (WASH 1250, 1973)

"The measures against the escape of radioactivity from nuclear facilities (nuclear power plants, fuel reprocessing waste disposal facilities, shipping, storage etc.) should use design features inherently favourable to safe operation e.g. by selection of fuel, coolant and core structural materials which will have inherent stability and safe characteristics."

In this paper a molten fuel fast breeder is discussed which could realise both these requirements through: - minimising the hazard of the escape of radioactive by substances by continuous extraction of the most volatile fission products from the molten fuel so that the steady state amounts of these are reduced by one or more orders of magnitude compared to the classical case of solid fuel periodically discharged and reprocessed.

It is well known that in the case of a reactor accident the hazards are centered around the volatile fission products (F.P.). For example according to Farmer (1973) a 1500 MW(th) reactor contains  $4 \times 10^9$  curies of volatile and gaseous

fission products of which I-131 equals 50 Megacuries. The hypothetical release having a very low probability of causing harm to the general public (unlikely to cause one case of fatal illness within the ensuing ten or more years) is of the order of 5 kilocuries of I-131. In a hypothetical low probability accident they discussed a release of 5 Megacuries of I-131 and 0.5 Megacuries of Cs-137.

## 2. Continuous gas extraction

The continuous in core gas extraction of volatile fission products from the liquid fuel is based on the following data and/or roughly estimated calculations (using the appropriate "GASEX" programme)

- a) the reactor is fuelled with molten salt fuel - in this case molten chlorides  $\text{PuCl}_3$  -  $\text{UCl}_3$  -  $\text{NaCl}$  etc. (fig. 1)
- b) the chemical properties of the fission products in this molten media are characterised by the scheme shown in (fig. 2)
- c) the balance of the fission products - especially for chlorine is given in (fig. 3)
- d) the thermodynamic stability of all the important irradiated fuel components are given in fig. 3
- e) the volatility (partial pressure) of some selected crucial fission products: e.g. caesium in the form of element, oxide and chloride is given in fig. 4



Fig. 2 Fission Products in Molten Chlorides Media

36	Kr	54	Xe	Gas Extraction	fast
35	Br	53	I		slow
34	Se	52	Te		very slow
33	As	51	Sb		Volatile chlorides
32	Ge	50	Sn		
31	Ga	49	In		Low volatile chlorides
30	Zn	48	Cd		
		47	Ag	Non volatile metals	
		46	Pd		
		45	Rh		
		44	Ru		
		43	Tc		
		42	Mo		
		41	Nb	Low volatile chlorides	
		40	Zr		
		64	Gd	Non volatile chlorides	
		63	Eu		
		62	Sm		
		61	Pm		
		60	Nd		
		59	Pr		
		58	Ce		
39	Y	57	La		
38	Sr	56	Ba	Low volatile chlorides	
37	Rb	55	Cs		

Fig. 3 Free Energy of Formation

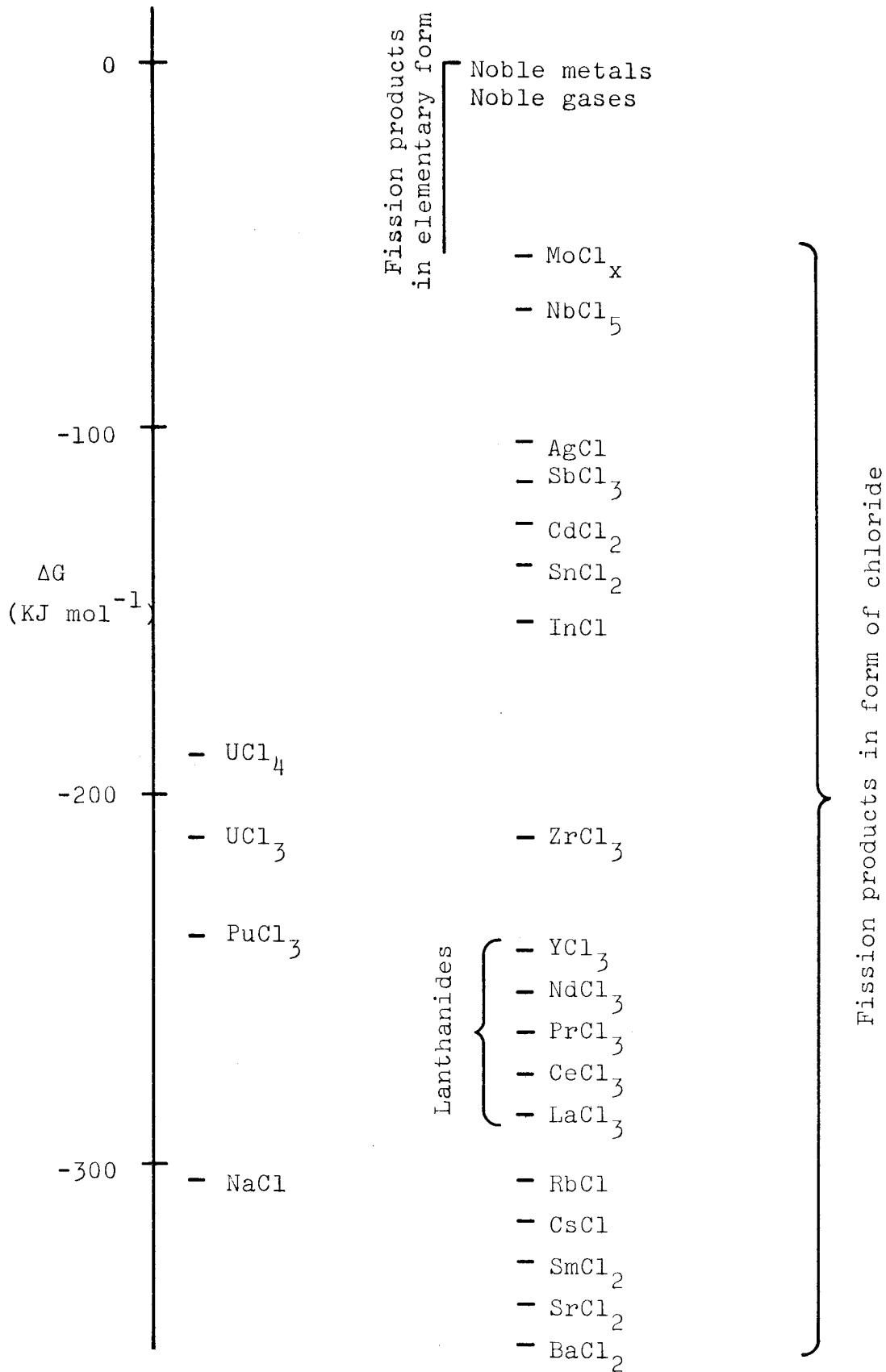



Fig. 4

Volatility Pressure of Caesium-metall (Caesium Oxide)  
and Caesium Chlorides

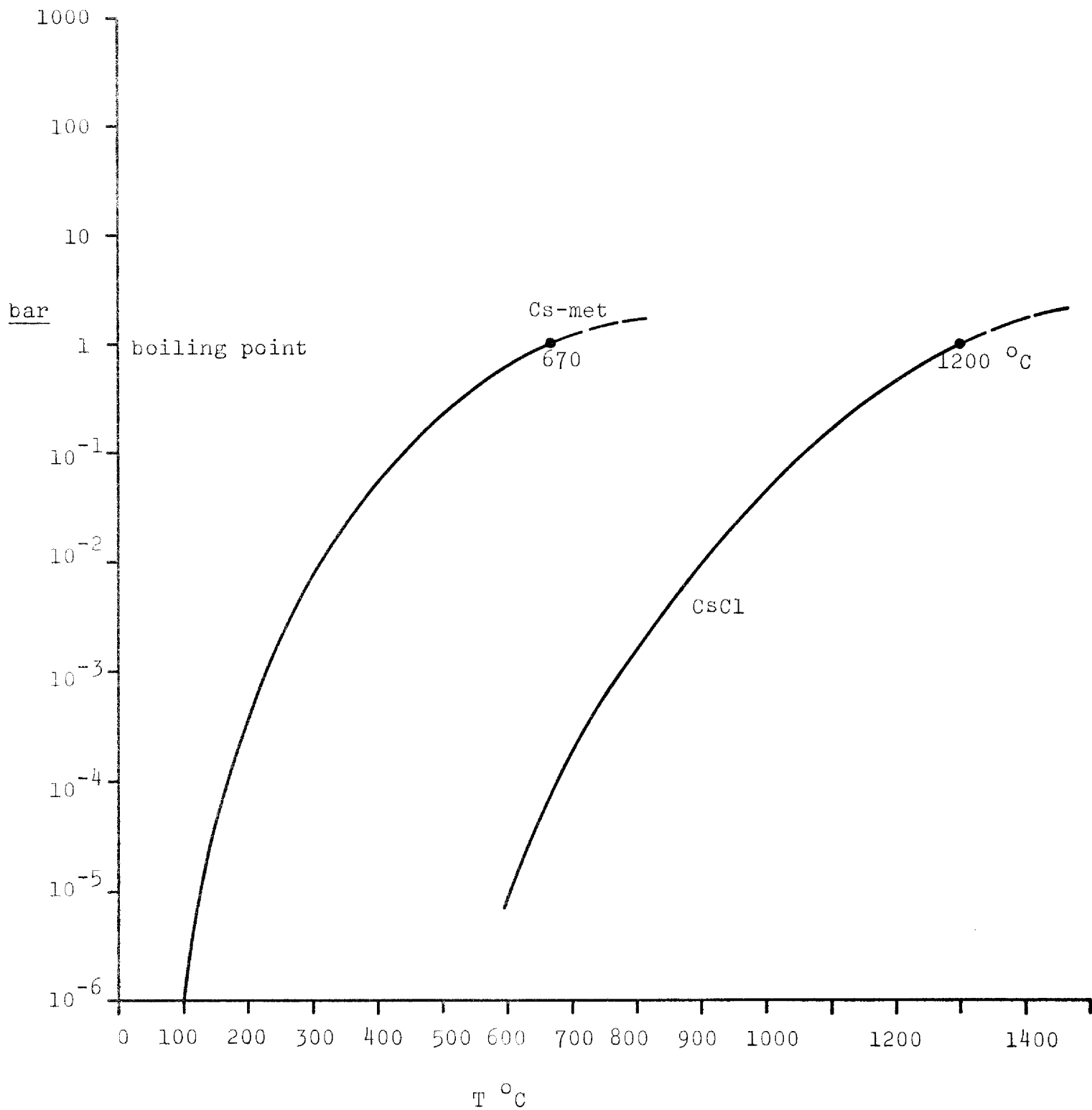

Fig. 5 Scheme of the independent Yield Calculation

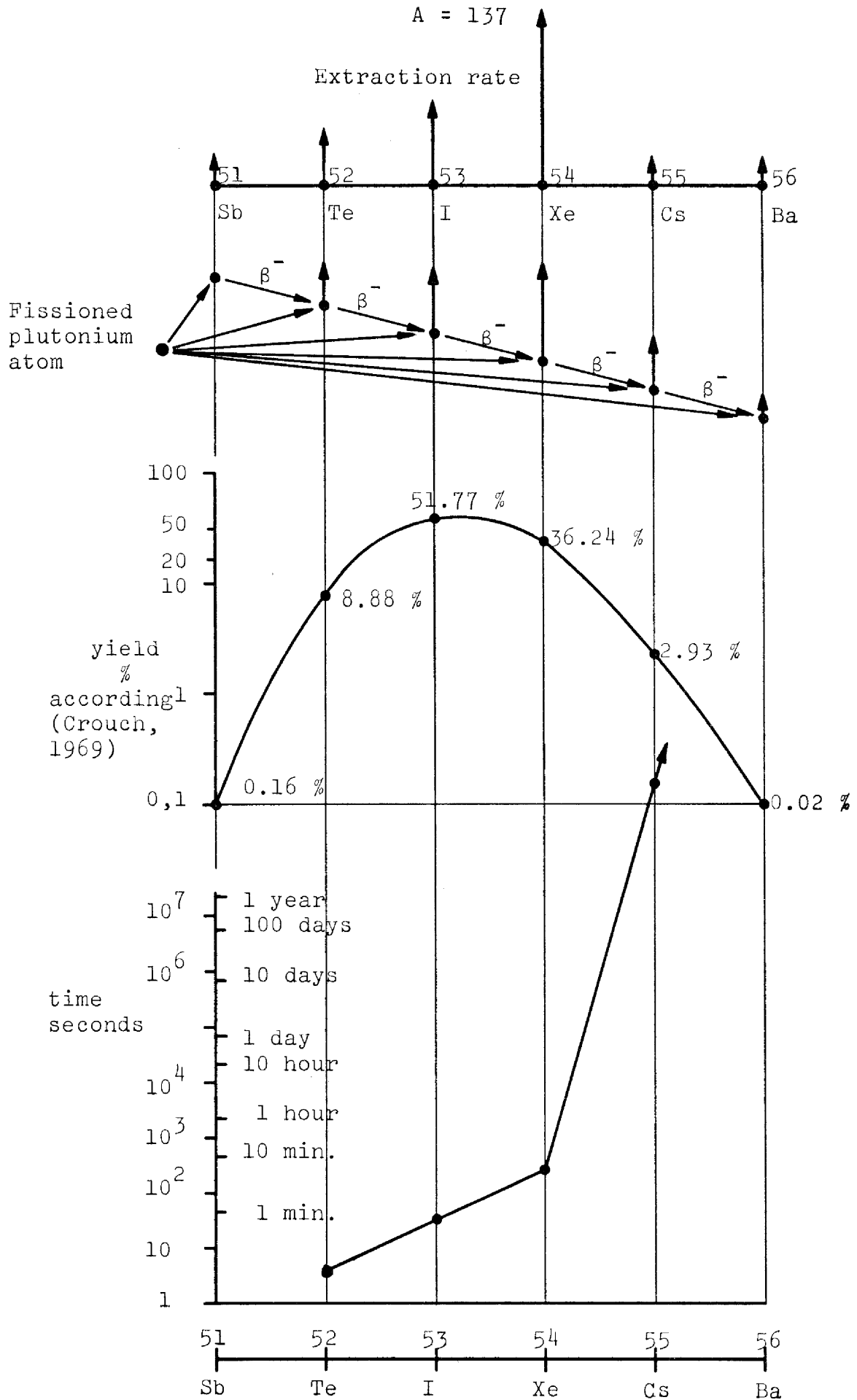
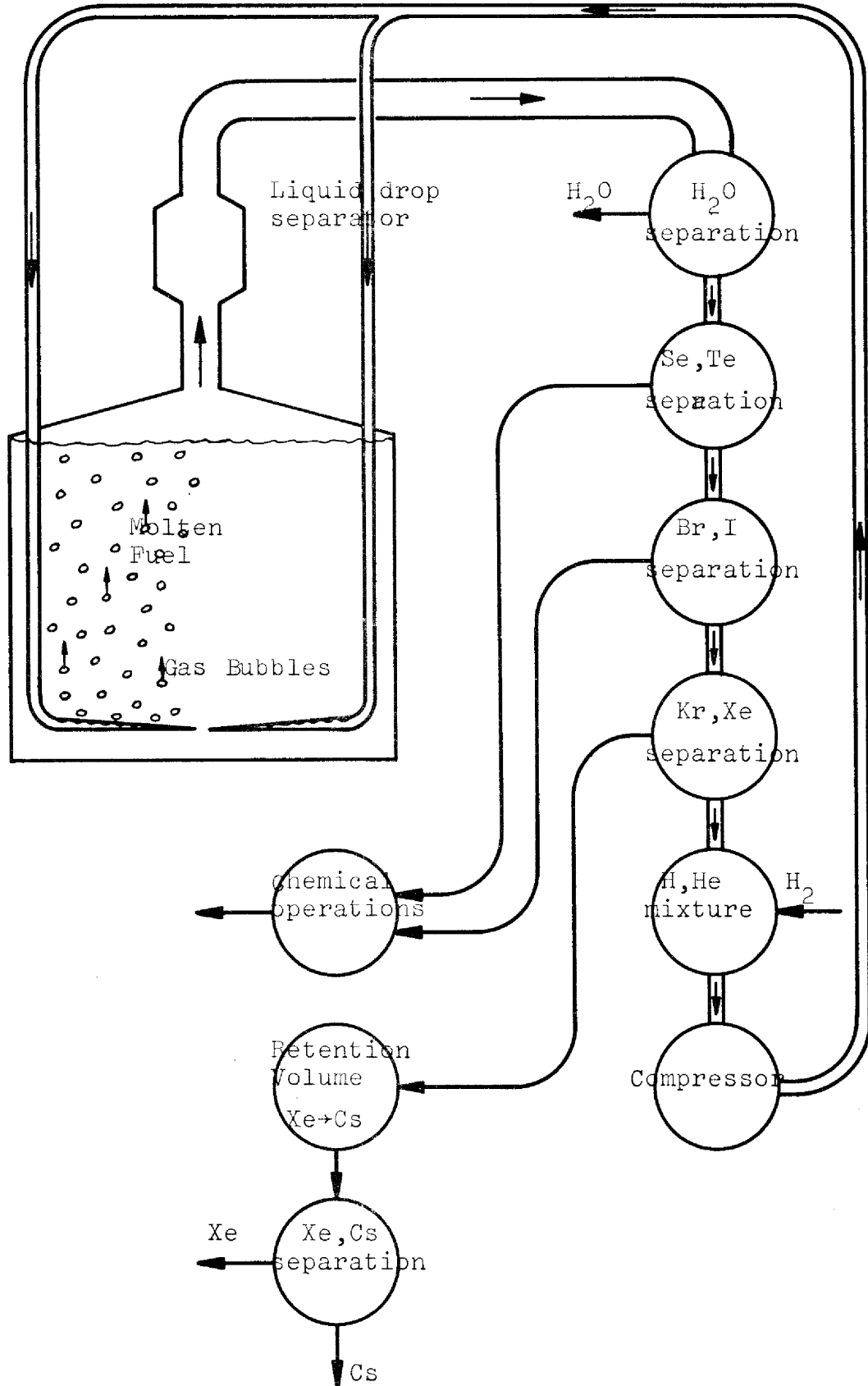

Fig. 6 Scheme of Gas-Extraction



- f) the history of each individual fission product is calculated on the basis of the independant yields: see fig. 5 (according to Crouch 1973)
- g) the in-core molten salt medium is purged by means of heliumhydrogen gas bubbles which greatly influence the chemical behaviour of some fission products (particularly iodine). The assumptions concerning the size of this stream is given in Appendix 1

### 3. Scheme of gas extraction and possible technology of gas separation

---

In order to give a basis for discussion on the gas extraction systems fig. 6 gives a simplified schematic. It must be stressed that this is a preliminary suggestion only without any basic studies.

### 4. Scheme of calculation

---

For calculation of the gas extraction system refered to here a computer programme "GASEX" has been prepared (using Fortran IV for the CDC 6500/6700). The principal layout on which the calculation is based is given in fig. 7.

Fig. 7 The Scheme of Calculation

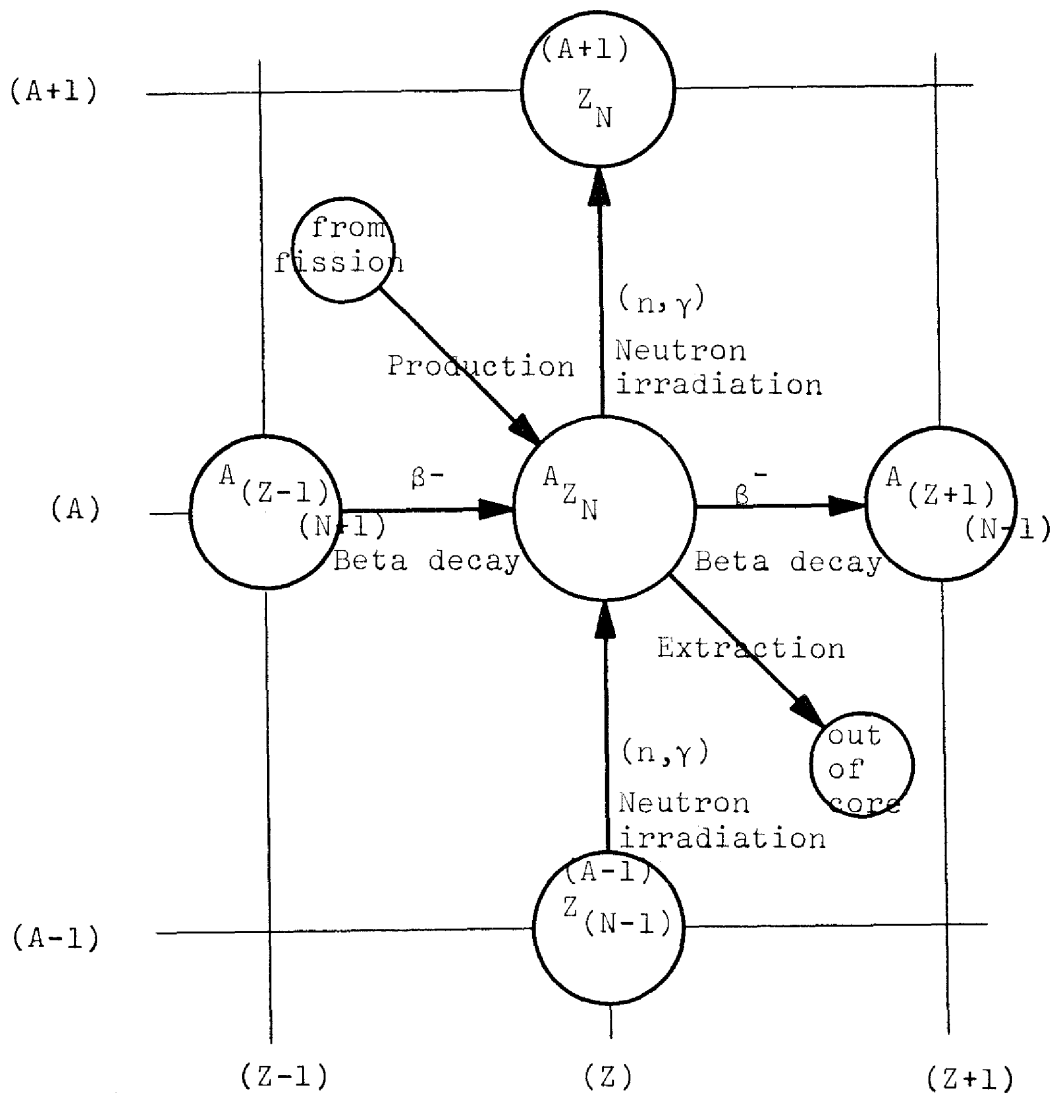
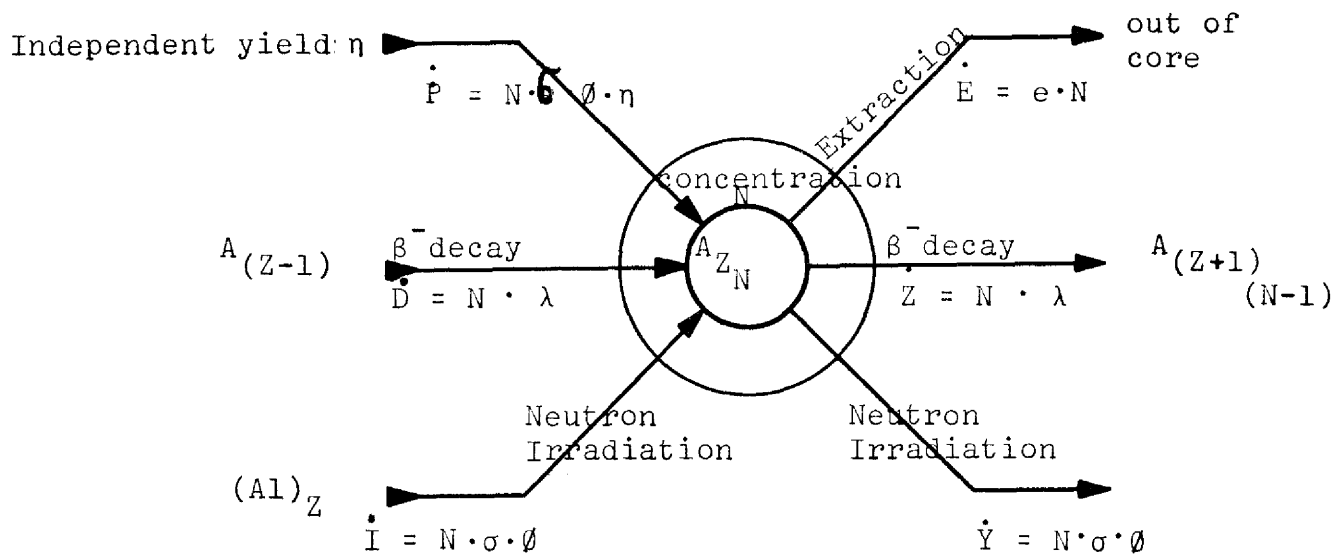

The only assumption arbitrarily made was the gas extraction rate of the volatile fission products.

The calculation was made for the following four assumptions, given in table 1.

Table 1 Core dwell time - (seconds)

	Variant			
	1	2	3	4
Se and Te	$10^6$	$10^9$	$10^4$	$10^3$
Br and I	$10^6$	$10^4$	$10^3$	$10^2$
Kr and Xe	$10^6$	$10^3$	$10^2$	$10^1$
All other elements *)	$10^6$	$10^6$	$10^6$	$10^6$

\*)  $10^6$  seconds equals 11.57 days which is postulated as the reprocessing period of the total liquid fuel

## 5. Results of the calculations

The most important results are:

1. Stable bromine isotopes A-79 and A-87 (fig. 8) are extracted with high efficiency.

The short lived isotopes ( $t_{1/2} \approx$  hours or minutes) (fig. 8) are extracted in rather small quantities (logarithmic vertical scale).

2. Short lived bromine isotopes  $A = 88, 89, 90$ , being also the probable precursors of delayed neutrons are in practice not extractable (no loss of delayed neutrons) (fig. 9 - linear vertical scale)
3. The very high retention of the heavy bromine isotopes in the molten fuel is almost independant of the rate of gas extraction. For the highest gas 'extraction' only a small extraction of bromine occurs (fig. 9).
4. The main problem for krypton isotopes is the Kr-85 (fig. 10). The gas extraction is successful for the lowest case (2) and results in a reduction of the amount of Kr-85 by approx 1000 times.

By increasing the gas extraction rate the amounts of this isotopes decreases by a factor  $10^{-5}$ . The short lived krypton isotopes are very efficiently extracted (fig. 11).

5. The gas extraction has only a small effect on the two radioactive strontium isotopes (fig. 12). They are decreased only by a factor of 7.
6. The case of the iodine isotopes (fig. 13 and 14) is critical for two reasons
  - I) the iodine-131 is an important factor in the core accident hazard.





ALL ISOTOPE OF ATOMICNUMBER 35

0.	GRAPH 1 -	ELEMENT BR	AT.NO. 35	ISOTOPE 88	HALF-LIFE 1.600E+01 SEC		
			2.00E-01	4.00E-01	6.00E-01	8.00E-01	1.00E+00
0.	GRAPH 2 -	ELEMENT BR	AT.NO. 35	ISOTOPE 89	HALF-LIFE 4.500E+00 SEC		
			2.00E-01	4.00E-01	6.00E-01	8.00E-01	1.00E+00
0.	GRAPH 3 -	ELEMENT BR	AT.NO. 35	ISOTOPE 90	HALF-LIFE 1.600E+00 SEC		
			2.00E-01	4.00E-01	6.00E-01	8.00E-01	1.00E+00

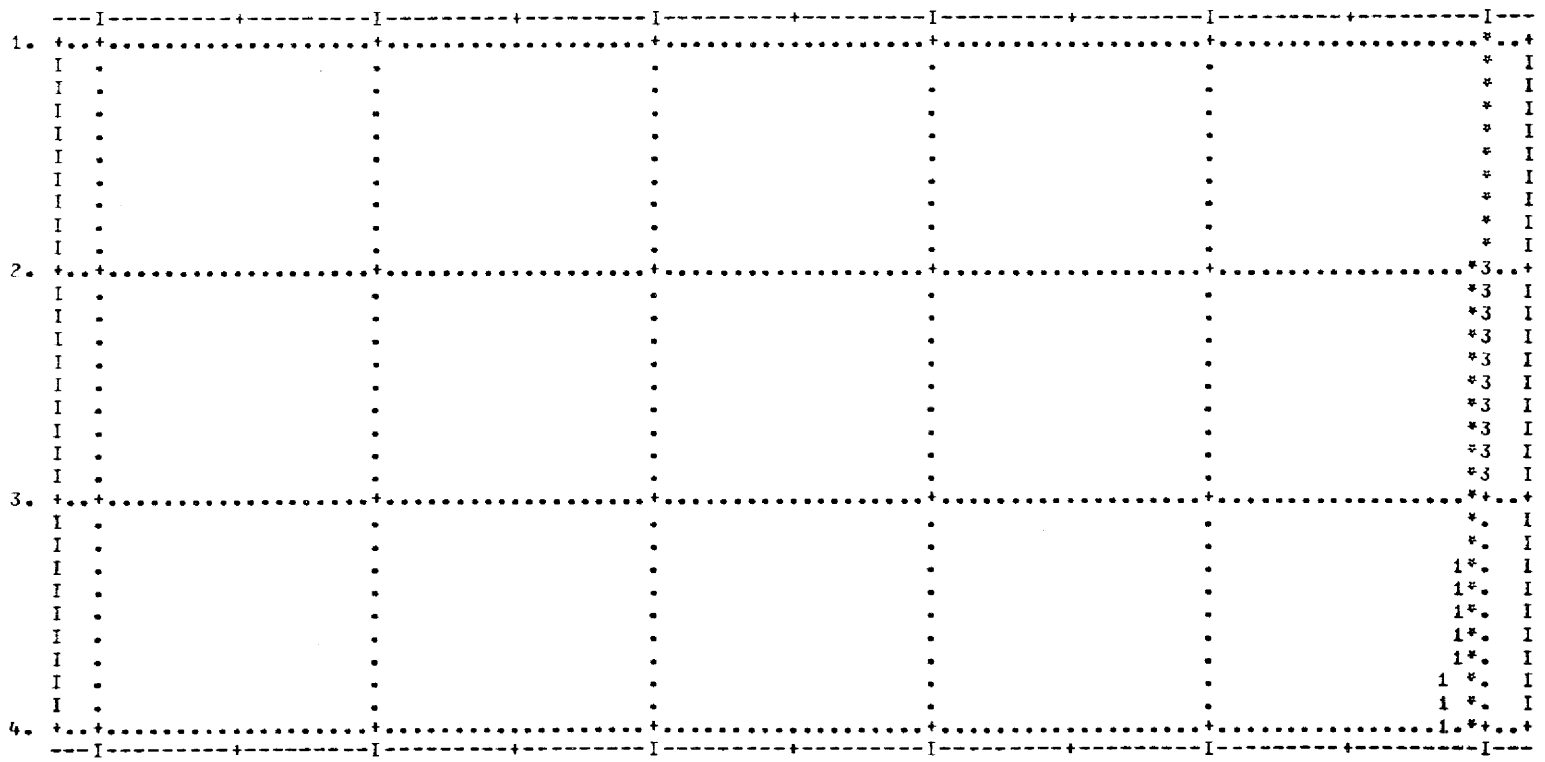

Fig. 9

ALL ISOTOPEs OF ATOMICNUMBER 36

GRAPH	ISOTOPE	AT.NO.	HALF-LIFE	STABILITY	1.00E+00	1.00E+02
1.00E-08	32	36	STABLE	1.00E-02	1.00E+00	1.00E+02
1.00E-08	83	36	STABLE	1.00E-02	1.00E+00	1.00E+02
1.00E-08	84	36	STABLE	1.00E-02	1.00E+00	1.00E+02
1.00E-08	85	36	HALF-LIFE 1.076E+01 YRS	1.00E-02	1.00E+00	1.00E+02
1.00E-08	86	36	STABLE	1.00E-02	1.00E+00	1.00E+02
1.00E-08	87	36	HALF-LIFE 7.600E+01 MIN	1.00E-02	1.00E+00	1.00E+02
1.00E-08	88	36	HALF-LIFE 2.800E+00 HRS	1.00E-02	1.00E+00	1.00E+02
1.00E-08	89	36	HALF-LIFE 3.100E+00 MIN	1.00E-02	1.00E+00	1.00E+02

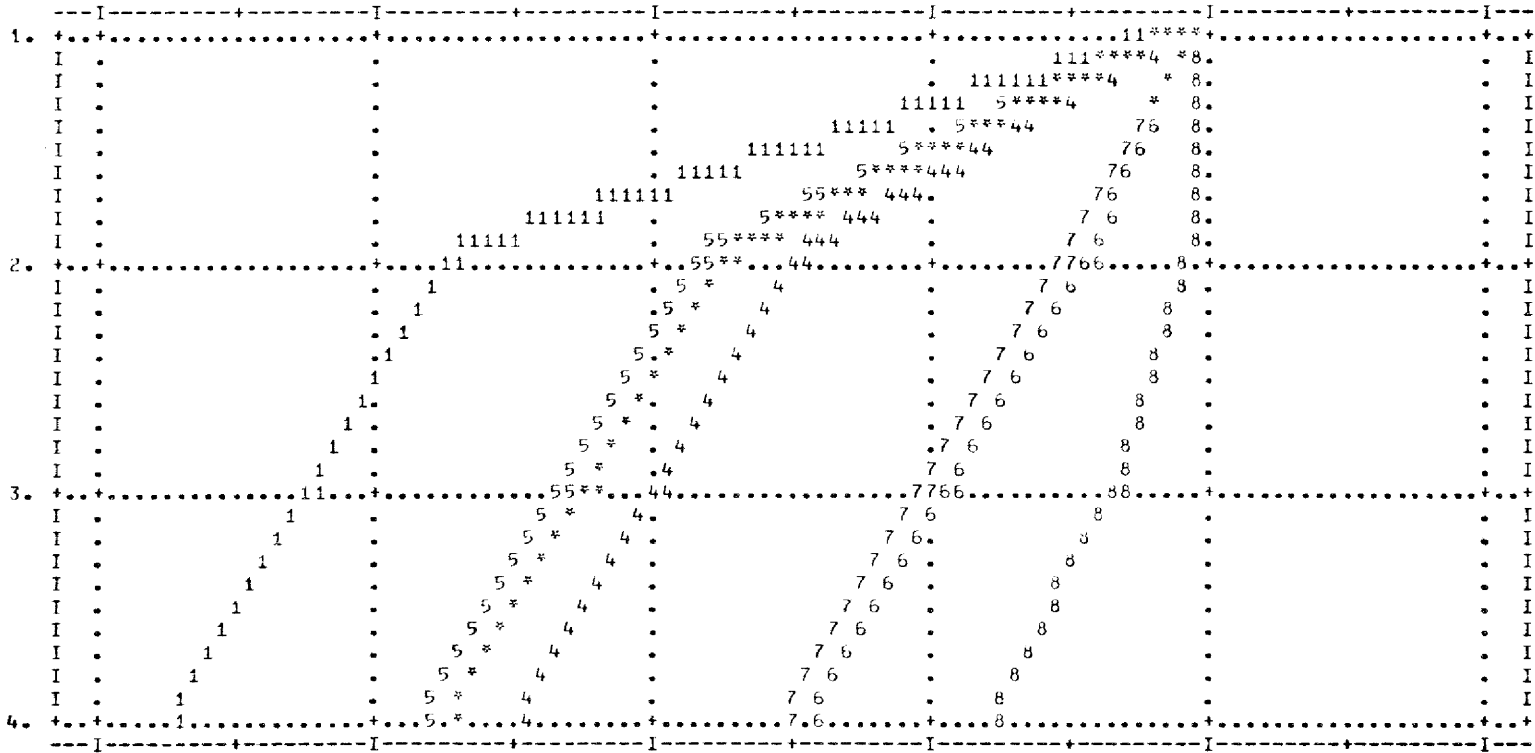

Fig. 10

ALL ISOTOPIES OF ATOMICNUMBER 36

GRAPH	1 -	ELEMENT KR	AT.NO. 36	ISOTOPE 90	HALF-LIFE 3.200E+01 SEC			
0.			2.00E-01	4.00E-01	6.00E-01	8.00E-01	1.00E+00	
0.	GRAPH 2 -	ELEMENT KR	AT.NO. 36	ISOTOPE 91	HALF-LIFE 8.400E+00 SEC			
			2.00E-01	4.00E-01	6.00E-01	8.00E-01	1.00E+00	
0.	GRAPH 3 -	ELEMENT KR	AT.NO. 36	ISOTOPE 92	HALF-LIFE 1.900E+00 SEC			
			2.00E-01	4.00E-01	6.00E-01	8.00E-01	1.00E+00	
0.	GRAPH 4 -	ELEMENT KR	AT.NO. 36	ISOTOPE 93	HALF-LIFE 1.200E+00 SEC			
			2.00E-01	4.00E-01	6.00E-01	8.00E-01	1.00E+00	
0.	GRAPH 5 -	ELEMENT KR	AT.NO. 36	ISOTOPE 94	HALF-LIFE 1.000E+00 SEC			
			2.00E-01	4.00E-01	6.00E-01	8.00E-01	1.00E+00	
0.	GRAPH 6 -	ELEMENT KR	AT.NO. 36	ISOTOPE 95	HALF-LIFE 8.000E-01 SEC			
			2.00E-01	4.00E-01	6.00E-01	8.00E-01	1.00E+00	

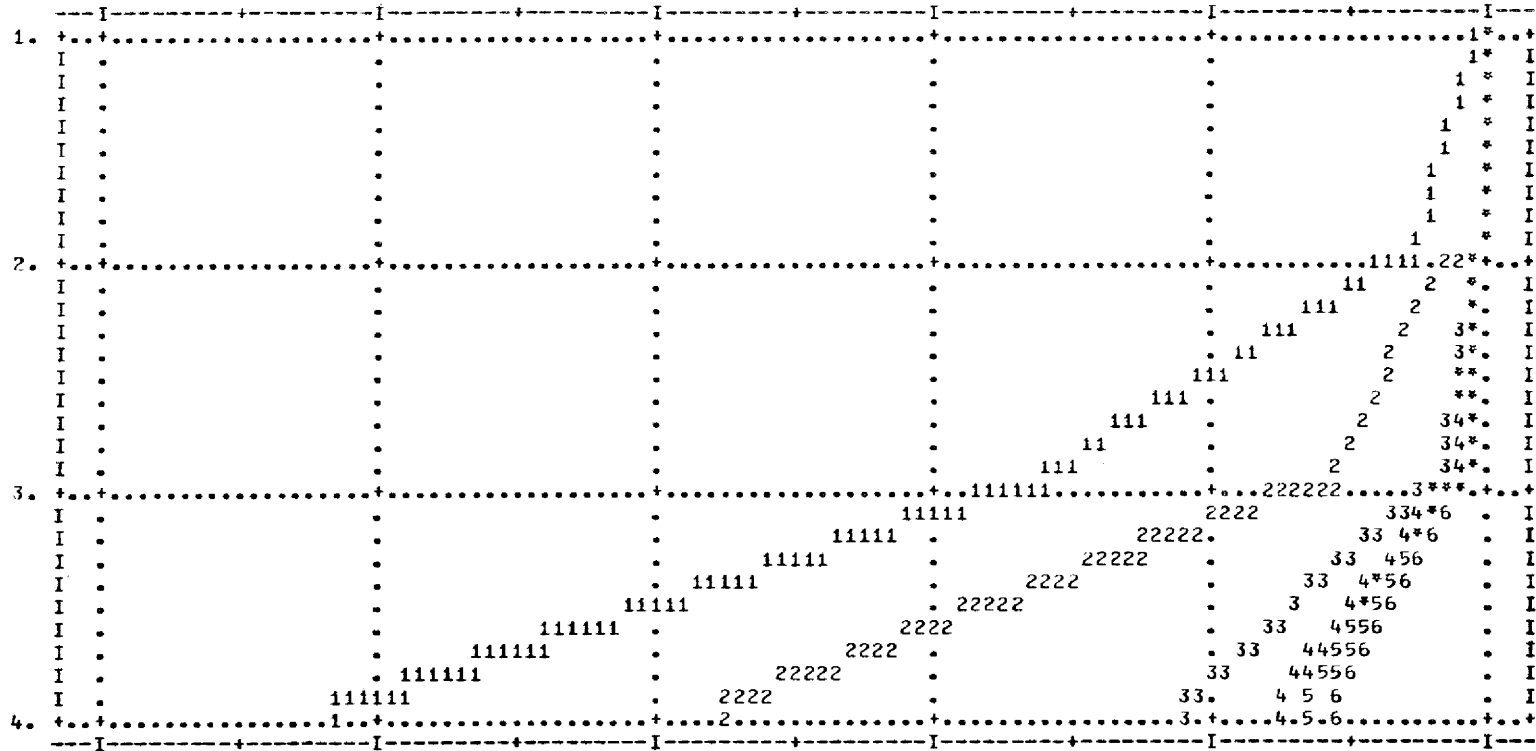

Fig. 11



ALL ISOTOPES OF ATOMICNUMBER 53

GRAPH	1 -	ELEMENT	J	AT.NO.	53	ISOTOPE	127	STABLE				
1.00E-08				1.00E-06		1.00E-04		1.00E-02		1.00E+00		1.00E+02
GRAPH	2 -	ELEMENT	J	AT.NO.	53	ISOTOPE	129	HALF-LIFE	1.700E+07	YRS		
1.00E-08				1.00E-06		1.00E-04		1.00E-02		1.00E+00		1.00E+02
GRAPH	3 -	ELEMENT	J	AT.NO.	53	ISOTOPE	130	HALF-LIFE	1.230E+01	HRS		
1.00E-08				1.00E-06		1.00E-04		1.00E-02		1.00E+00		1.00E+02
GRAPH	4 -	ELEMENT	J	AT.NO.	53	ISOTOPE	131	HALF-LIFE	8.050E+00	DAY		
1.00E-08				1.00E-06		1.00E-04		1.00E-02		1.00E+00		1.00E+02
GRAPH	5 -	ELEMENT	J	AT.NO.	53	ISOTOPE	132	HALF-LIFE	2.400E+00	HRS		
1.00E-08				1.00E-06		1.00E-04		1.00E-02		1.00E+00		1.00E+02
GRAPH	6 -	ELEMENT	J	AT.NO.	53	ISOTOPE	133	HALF-LIFE	2.980E+01	HRS		
1.00E-08				1.00E-06		1.00E-04		1.00E-02		1.00E+00		1.00E+02
GRAPH	7 -	ELEMENT	J	AT.NO.	53	ISOTOPE	134	HALF-LIFE	5.200E+01	MIN		
1.00E-08				1.00E-06		1.00E-04		1.00E-02		1.00E+00		1.00E+02
GRAPH	8 -	ELEMENT	J	AT.NO.	53	ISOTOPE	135	HALF-LIFE	6.700E+00	HRS		
1.00E-08				1.00E-06		1.00E-04		1.00E-02		1.00E+00		1.00E+02

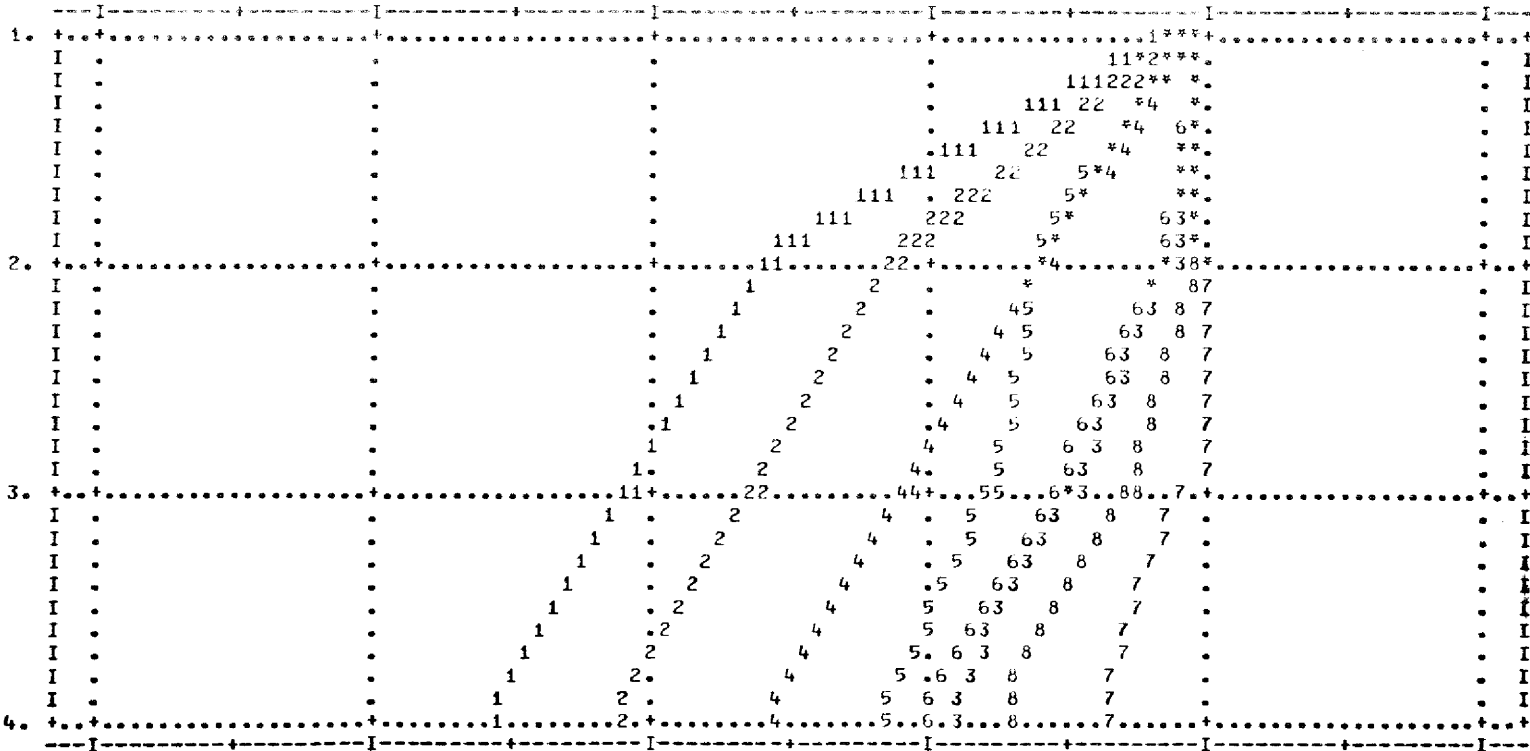

Fig. 13

ALL ISOTOPES OF ATOMICNUMBER 53

0.	GRAPH 1 -	ELEMENT J	AT.NO. 53	ISOTOPE 136	HALF-LIFE 8.300E+01 SEC		
						8.00E-01	1.00E+00
0.	GRAPH 2 -	ELEMENT J	AT.NO. 53	ISOTOPE 137	HALF-LIFE 2.400E+01 SEC		
						8.00E-01	1.00E+00
0.	GRAPH 3 -	ELEMENT J	AT.NO. 53	ISOTOPE 138	HALF-LIFE 6.000E+00 SEC		
						8.00E-01	1.00E+00
0.	GRAPH 4 -	ELEMENT J	AT.NO. 53	ISOTOPE 139	HALF-LIFE 2.700E+00 SEC		
						8.00E-01	1.00E+00
0.	GRAPH 5 -	ELEMENT J	AT.NO. 53	ISOTOPE 140	HALF-LIFE 8.000E-01 SEC		
						8.00E-01	1.00E+00

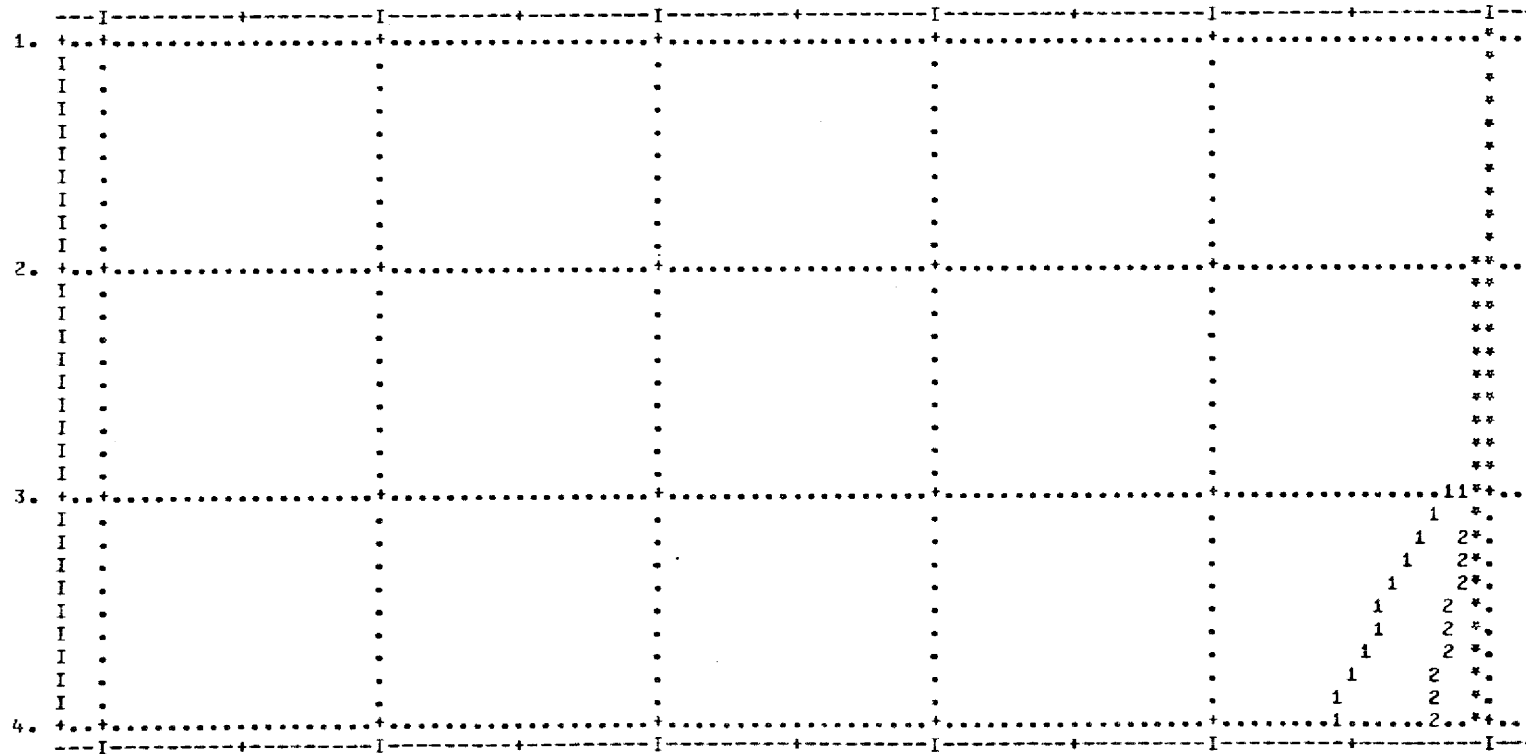

Fig. 14

ALL ISOTOPES OF ATOMICNUMBER 54

GRAPH	ELEMENT	AT.NO.	ISOTOPE	PROPERTY	1.00E-02	1.00E+00	1.00E+02
1.00E-08	1 - ELEMENT XE	AT.NO. 54	ISOTOPE 129	STABLE	1.00E-02	1.00E+00	1.00E+02
1.00E-08	2 - ELEMENT XE	AT.NO. 54	ISOTOPE 130	STABLE	1.00E-02	1.00E+00	1.00E+02
1.00E-08	3 - ELEMENT XE	AT.NO. 54	ISOTOPE 131	STABLE	1.00E-02	1.00E+00	1.00E+02
1.00E-08	4 - ELEMENT XE	AT.NO. 54	ISOTOPE 132	STABLE	1.00E-02	1.00E+00	1.00E+02
1.00E-08	5 - ELEMENT XE	AT.NO. 54	ISOTOPE 133	HALF-LIFE 5.650E+00 DAY	1.00E-02	1.00E+00	1.00E+02
1.00E-08	6 - ELEMENT XE	AT.NO. 54	ISOTOPE 134	STABLE	1.00E-02	1.00E+00	1.00E+02
1.00E-08	7 - ELEMENT XE	AT.NO. 54	ISOTOPE 135	HALF-LIFE 9.150E+00 HRS	1.00E-02	1.00E+00	1.00E+02
1.00E-08	8 - ELEMENT XE	AT.NO. 54	ISOTOPE 136	STABLE	1.00E-02	1.00E+00	1.00E+02

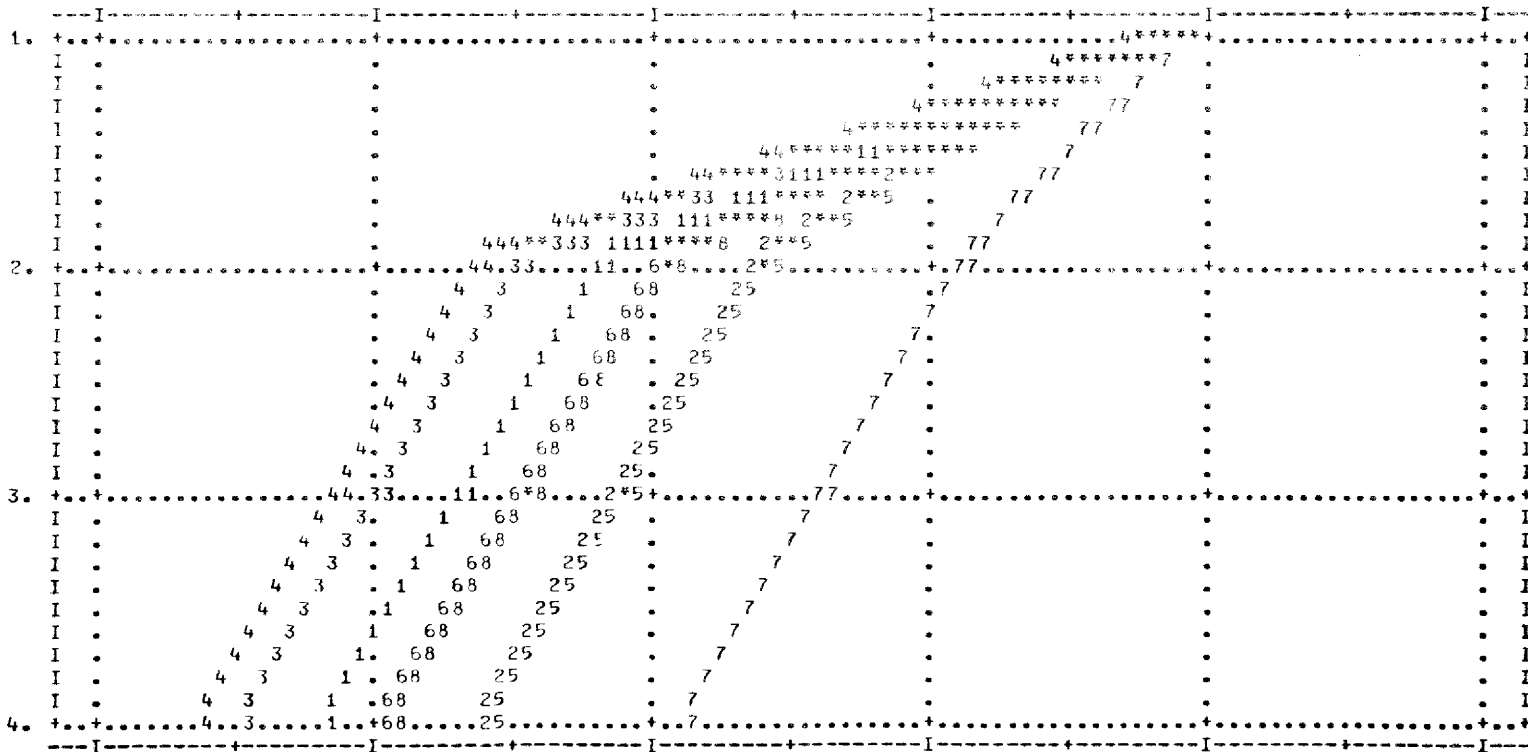

Fig. 15

ELEMENT XE WITH AT.NO. 54 - ISOTOPE 144 HALF-LIFE 1.000E+00 SEC HAS RM = INDEF.

ALL ISOTOPES OF ATOMICNUMBER 54

GRAPH	ISOTOPE	HALF-LIFE	1.00E+00	1.00E+02
1 - ELEMENT XE AT.NO. 54 ISOTOPE 137	137	3.900E+00 MIN	1.00E+00	1.00E+02
1.00E-08	1.00E-06	1.00E-04	1.00E-02	
2 - ELEMENT XE AT.NO. 54 ISOTOPE 138	138	1.410E+01 MIN	1.00E+00	1.00E+02
1.00E-08	1.00E-06	1.00E-04	1.00E-02	
3 - ELEMENT XE AT.NO. 54 ISOTOPE 139	139	4.100E+01 SEC	1.00E+00	1.00E+02
1.00E-08	1.00E-06	1.00E-04	1.00E-02	
4 - ELEMENT XE AT.NO. 54 ISOTOPE 140	140	1.350E+01 SEC	1.00E+00	1.00E+02
1.00E-08	1.00E-06	1.00E-04	1.00E-02	
5 - ELEMENT XE AT.NO. 54 ISOTOPE 141	141	1.700E+00 SEC	1.00E+00	1.00E+02
1.00E-08	1.00E-06	1.00E-04	1.00E-02	
6 - ELEMENT XE AT.NO. 54 ISOTOPE 142	142	1.200E+00 SEC	1.00E+00	1.00E+02
1.00E-08	1.00E-06	1.00E-04	1.00E-02	
7 - ELEMENT XE AT.NO. 54 ISOTOPE 143	143	1.000E+00 SEC	1.00E+00	1.00E+02
1.00E-08	1.00E-06	1.00E-04	1.00E-02	

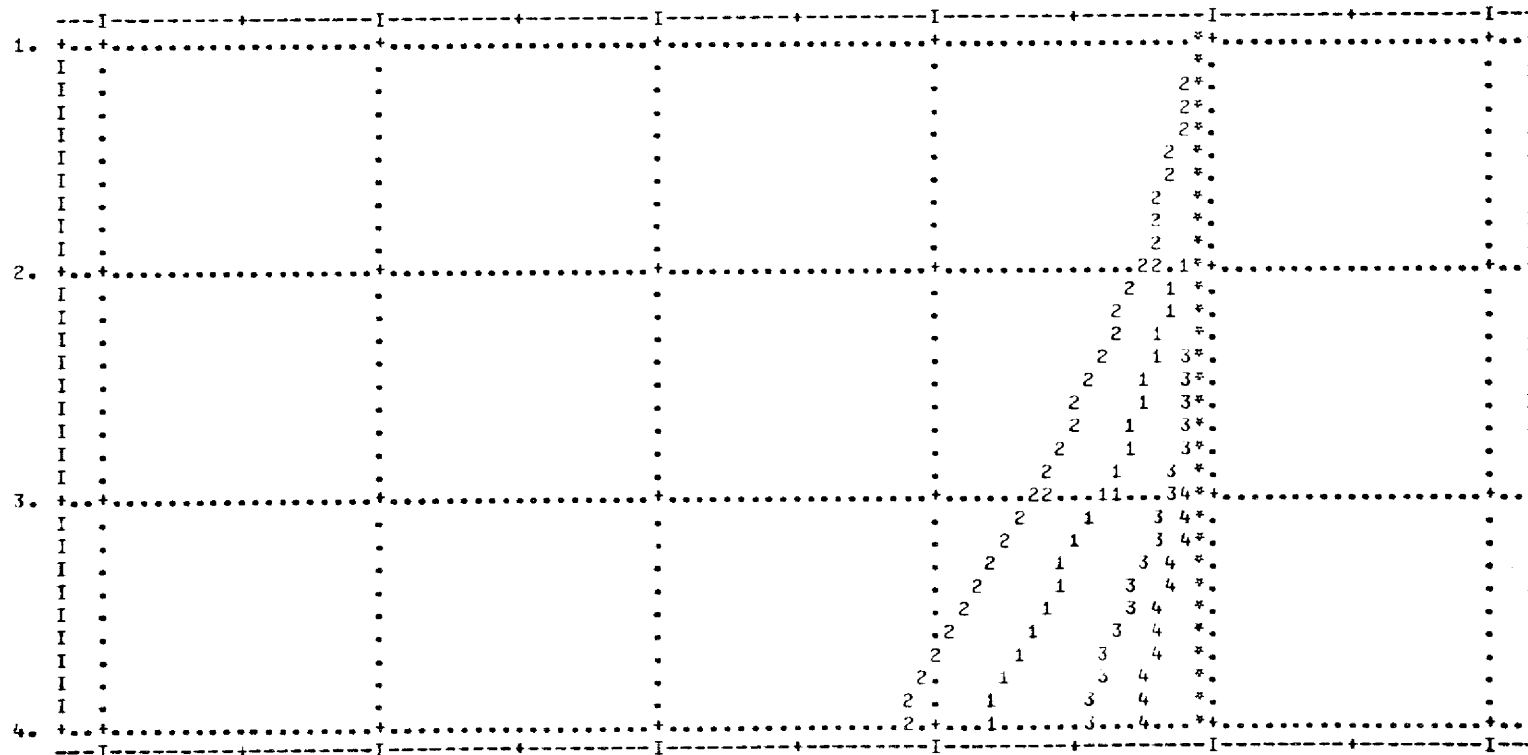

Fig. 16



ALL ISOTOPES OF ATOMICNUMBER 55

1.00E-08	GRAPH 1 -	ELEMENT CS	AT.NO. 55	ISOTOPE 133	STABLE	1.00E-02	1.00E+00	1.00E+02
1.00E-08	GRAPH 2 -	ELEMENT CS	AT.NO. 55	ISOTOPE 135	HALF-LIFE 2.000E+06 YRS	1.00E-02	1.00E+00	1.00E+02
1.00E-08	GRAPH 3 -	ELEMENT CS	AT.NO. 55	ISOTOPE 137	HALF-LIFE 3.000E+01 YRS	1.00E-02	1.00E+00	1.00E+02
1.00E-08	GRAPH 4 -	ELEMENT CS	AT.NO. 55	ISOTOPE 138	HALF-LIFE 3.230E+01 MIN	1.00E-02	1.00E+00	1.00E+02
1.00E-08	GRAPH 5 -	ELEMENT CS	AT.NO. 55	ISOTOPE 139	HALF-LIFE 9.000E+00 MIN	1.00E-02	1.00E+00	1.00E+02

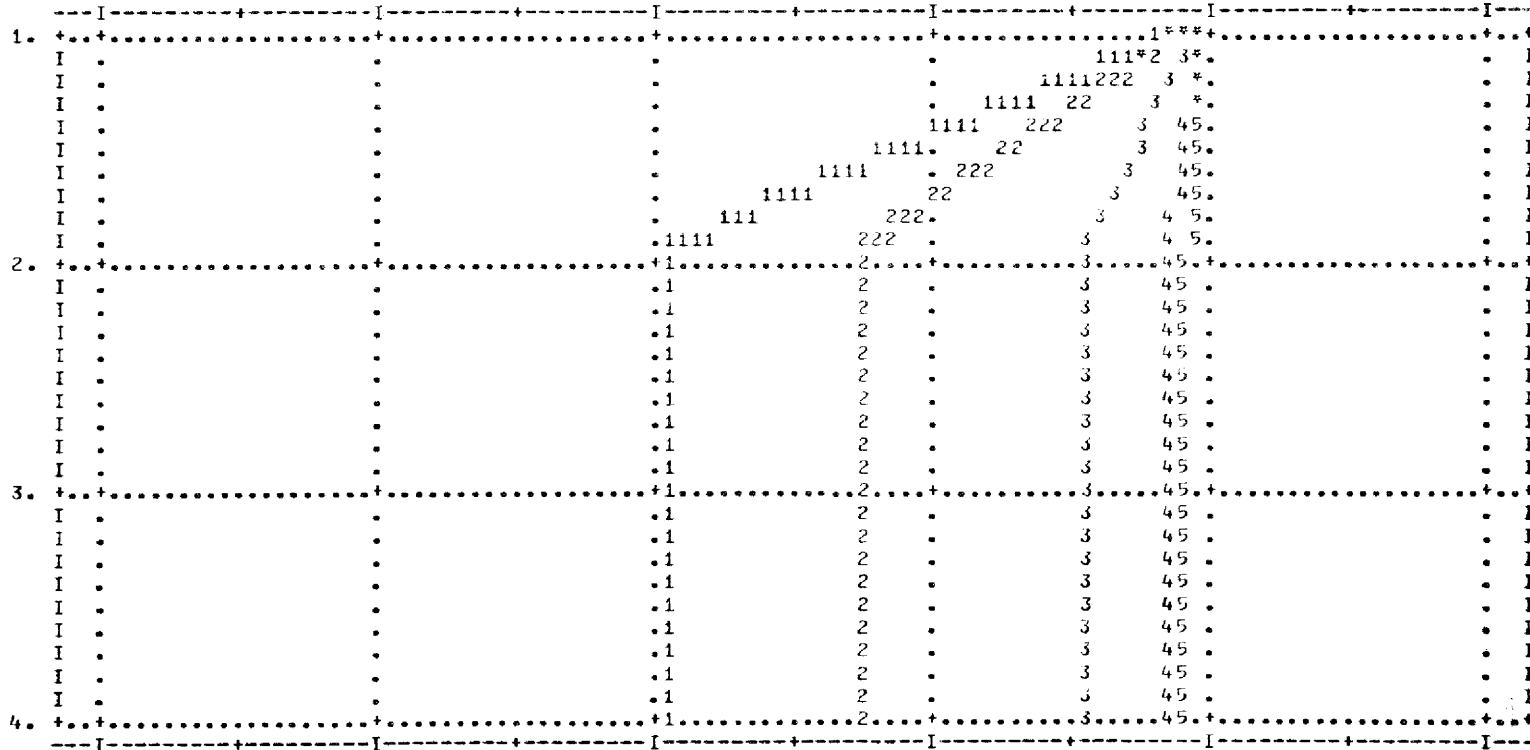

Fig. 17

II) The isotopes I-136, I-137, I-138, I-139 and I-140 are probably the most efficient precursors of delayed neutrons.

Fig. 13 shows that the gas extraction of I-131 is very efficient but rather strongly dependant on the postulated gas extraction rate. For the lowest rate the I-131 decreases by a factor of approx 10, but for the middle case - variant 3 this factor increases to more than 100 and for the highest rate (4) reaches approx 1000. For the same gas extraction rates the loss of iodine isotope delayed neutron precursors is negligible (see iodine-136 - 140, fig. 14).

7. The xenon isotopes are also an important factor in the core accident hazard. Gas extraction decreases the amount of xenon in the core significantly including the long lived Xe-133 and Xe-135 (fig. 15 and 16). The short life xenon isotopes are only slightly influenced by the gas extraction.
8. The next controlling radionuclide is Cs-137. From fig. 17 it is seen that the gas extraction does not aid in the removal of this nuclide from the molten fuel, a factor of 7 is all that can be obtained. But the amount is not the only important factor, the volatility of caesium is also of interest.

From fig. 4 it is clear that the caesium chloride has a much lower partial pressure than that of caesium metal or caesium oxide in the same temperature range.

A very important problem arises with the possibility of the nuclear transformation of fission products.

ALL ISOTOPE WITH HALF-LIFE BETWEEN 0.3 AND 3 Y

GRAPH 1	ELEMENT RU	AT.NO. 44	ISOTOPE 106	HALF-LIFE 1.000E+00 YRS		
1.00E-08		1.00E-06	1.00E-04	1.00E-02	1.00E+00	1.00E+02
GRAPH 2	ELEMENT SB	AT.NO. 51	ISOTOPE 125	HALF-LIFE 2.700E+00 YRS		
1.00E-08		1.00E-06	1.00E-04	1.00E-02	1.00E+00	1.00E+02
GRAPH 3	ELEMENT CE	AT.NO. 58	ISOTOPE 144	HALF-LIFE 2.840E+02 DAY		
1.00E-08		1.00E-06	1.00E-04	1.00E-02	1.00E+00	1.00E+02
GRAPH 4	ELEMENT PM	AT.NO. 61	ISOTOPE 147	HALF-LIFE 2.620E+00 YRS		
1.00E-08		1.00E-06	1.00E-04	1.00E-02	1.00E+00	1.00E+02
GRAPH 5	ELEMENT EU	AT.NO. 63	ISOTOPE 155	HALF-LIFE 1.810E+00 YRS		
1.00E-08		1.00E-06	1.00E-04	1.00E-02	1.00E+00	1.00E+02

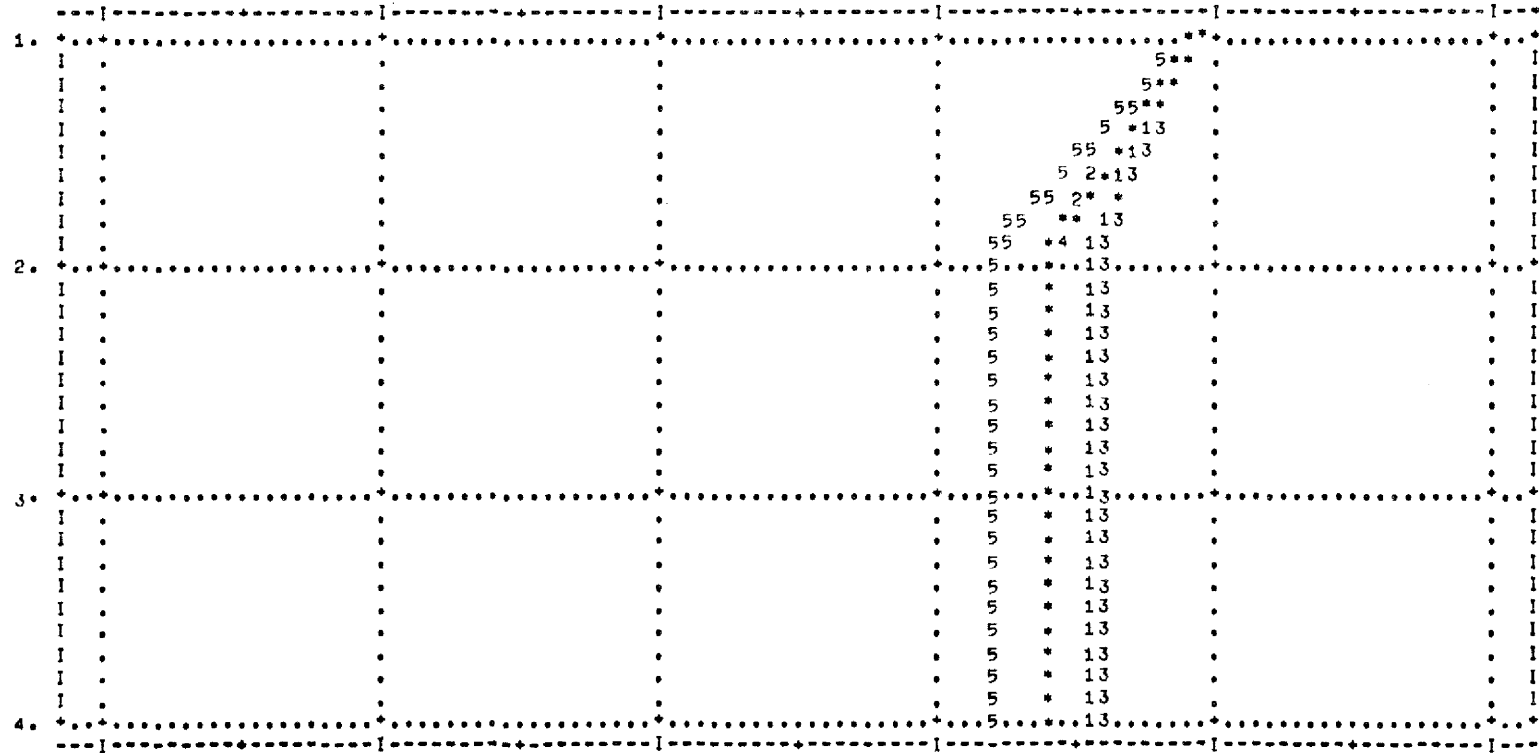

Fig. 18

N36 WITH IS85,N54 WITH IS135,N55 WITH IS137

1.00E-08	GRAPH 1 -	ELEMENT KR	AT.NO. 36	ISOTOPE 85	HALF-LIFE 1.076E+01 YRS	1.00E+00	1.00E+02
1.00E+08	GRAPH 2 -	ELEMENT XE	AT.NO. 54	ISOTOPE 135	HALF-LIFE 9.150E+00 HRS	1.00E+00	1.00E+02
1.00E+08	GRAPH 3 -	ELEMENT CS	AT.NO. 55	ISOTOPE 137	HALF-LIFE 3.000E+01 YRS	1.00E+00	1.00E+02

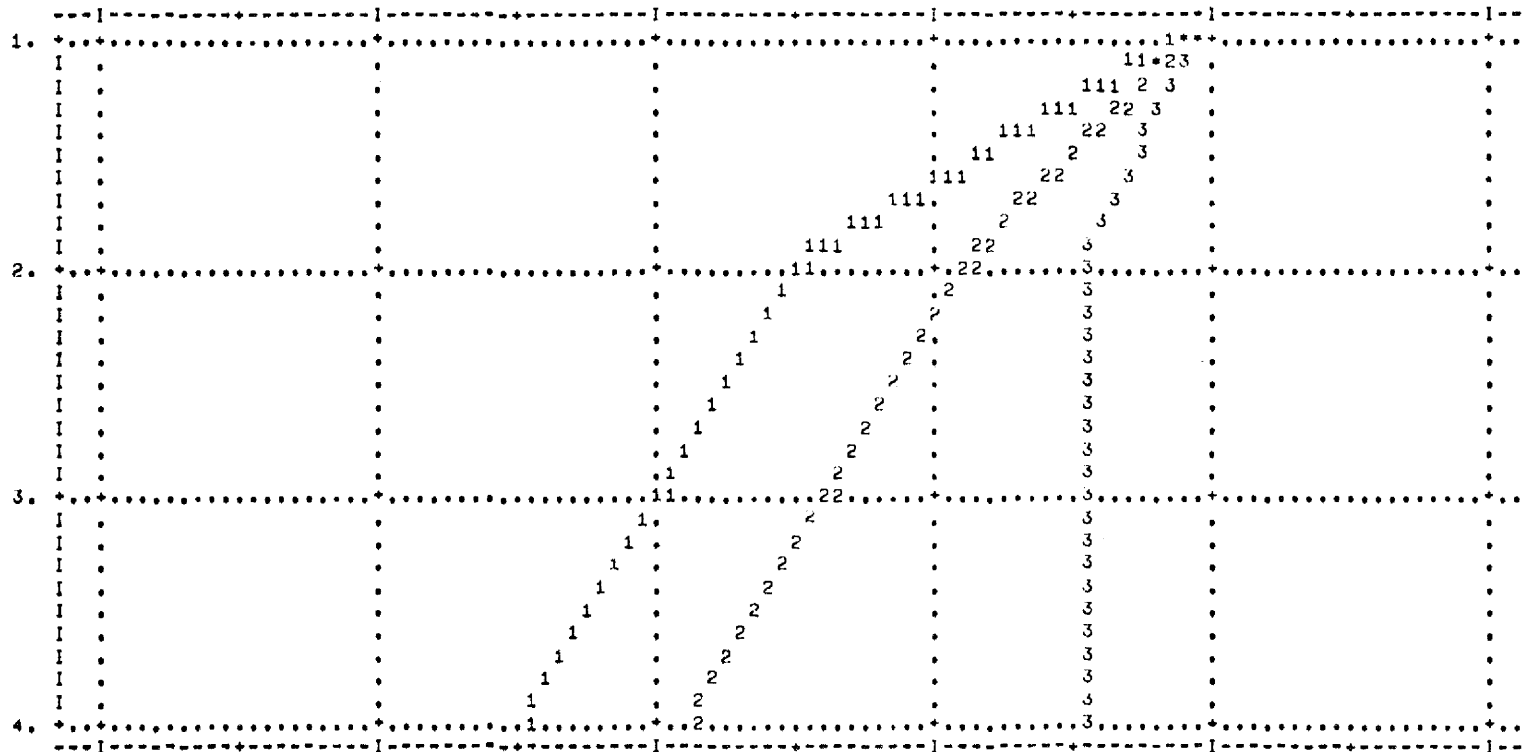

Fig. 19

One of the methods especially for Cs-137 and Sr-90 is their irradiation in a fast high flux reactor. (The use of fast reactors is important because the absorption cross sections for thermal neutrons are relatively small - 0.1 and 0.8 barns.) It is important that the nuclide in question is more or less isotopically pure for two reasons

I) the neutron absorption in other isotopes

II) the increased volume.

In the case of caesium there are three isotopes of importance for neutron irradiation techniques they are: (yield for fast fission of Pu-239)

Cs-135	stable	yield 6.91 atom %
Cs-135	t 1/2 - $2.1 \times 10^6$ years	yield 7.54 atom %
Cs-137	t 1/2 - 30 years	yield 6.69 atom %

If isotopic separation is not possible the amount of caesium for neutron irradiation must be approx 3.15 times bigger than for pure Cs-137 and the macroscopic absorption cross section is probably more than 20 times bigger.

With the continuous in-core gas extraction system proposed here the separation of caesium isotopes - particularly Cs-137 from Cs-135 (long lived) and Cs-133 (stable) is possible, as is described elsewhere (Taube 1974).

8. Other nuclides with 'mean life times' greater than 0.3 years and shorter than 3 years as shown in fig. 18 - that is Ru-106, Sb-125, Ce-144, Pm-147 and Eu-155 are all little affected by the gas extraction.

9. Fig. 19 shows the most hazardous nuclides together Kr-85, Sr-90, Xe-135, Cs-137.
10. Fig. 20, 21, 22 show the estimated values of radioactivity for some selected nuclides in a 2000 MW(th) fast reactor for different cases
  - a) without continuous gas extraction and with 85 days irradiation period.
  - b) with gas extraction at the highest rate
  - c) with gas extraction at the lowest rate.

### Conclusions

The model of a possible continuous in-core gas-extraction process described here for a core fuelled by molten chlorides has the following features.

1. The extraction rate of the precursors of the delayed neutrons can be reduced to an insignificant value - even if these are very volatile. e.g. Kr, Xe, Br, I etc.
2. The extraction rate of I-131, the most hazardous fission product, prominent in any severe core-accident, is so high that the steady state concentration of this nuclide is reduced by more than 1000 times which significantly improves the reactor safety.

Fig. 20 Krypton-85

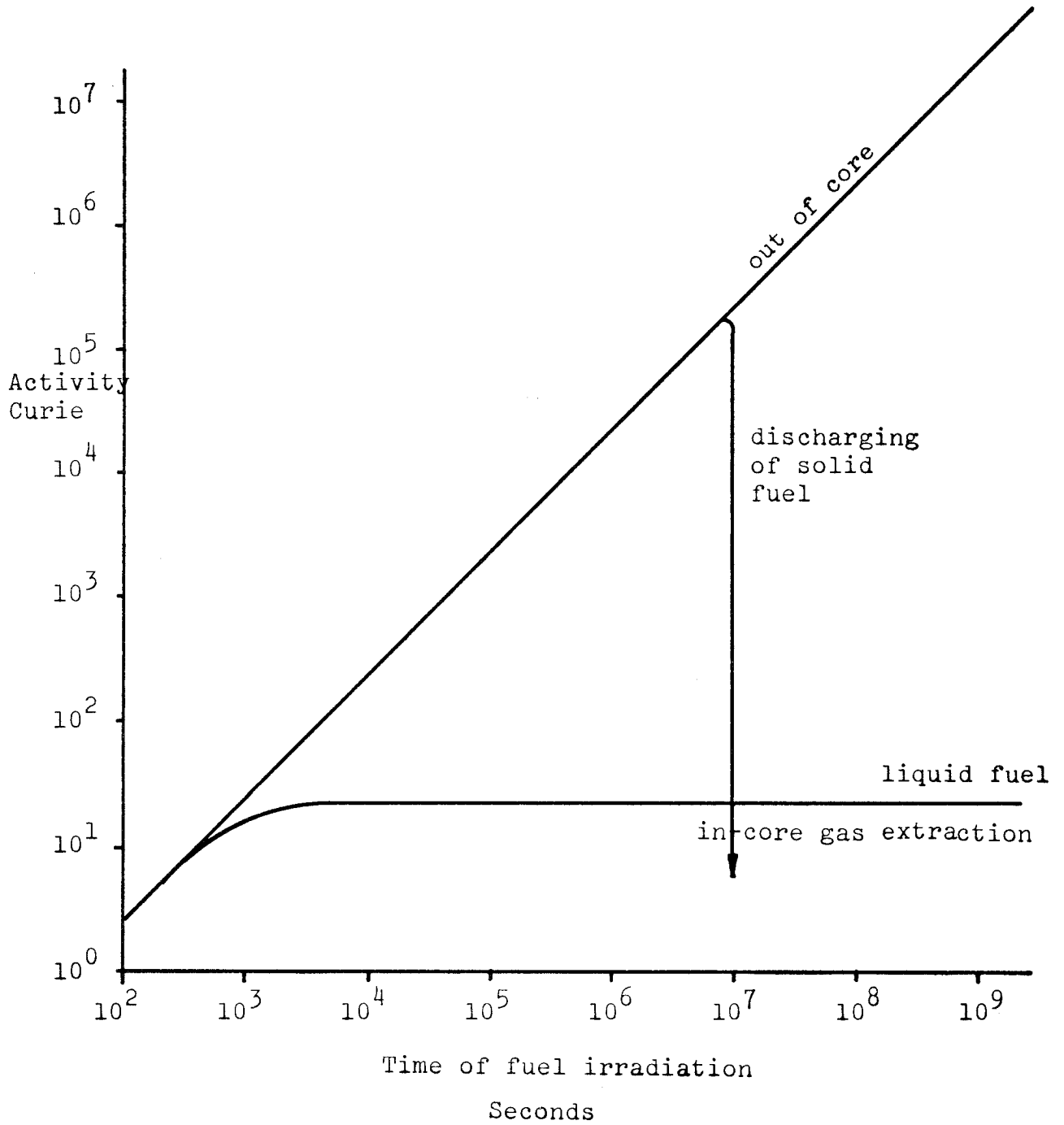
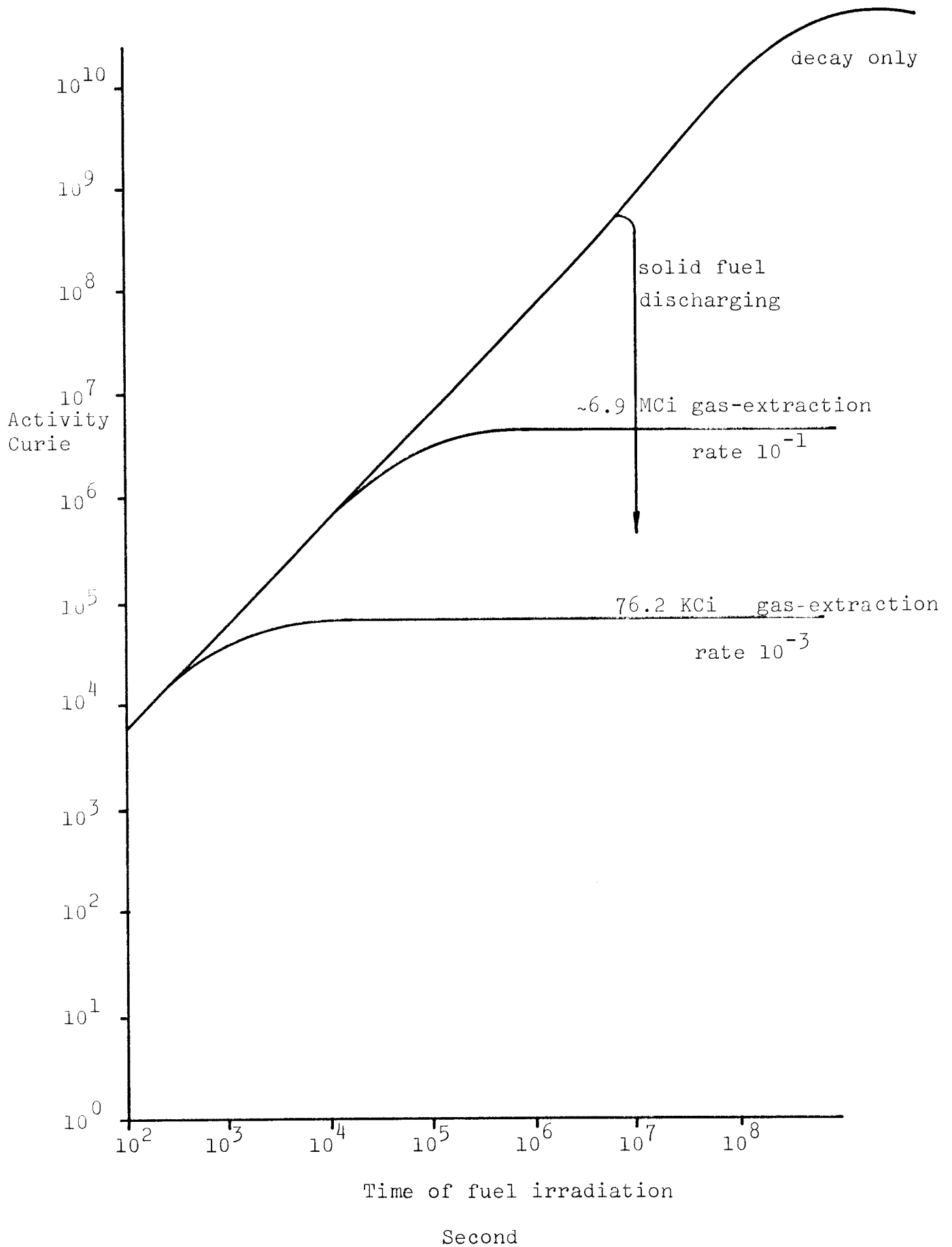
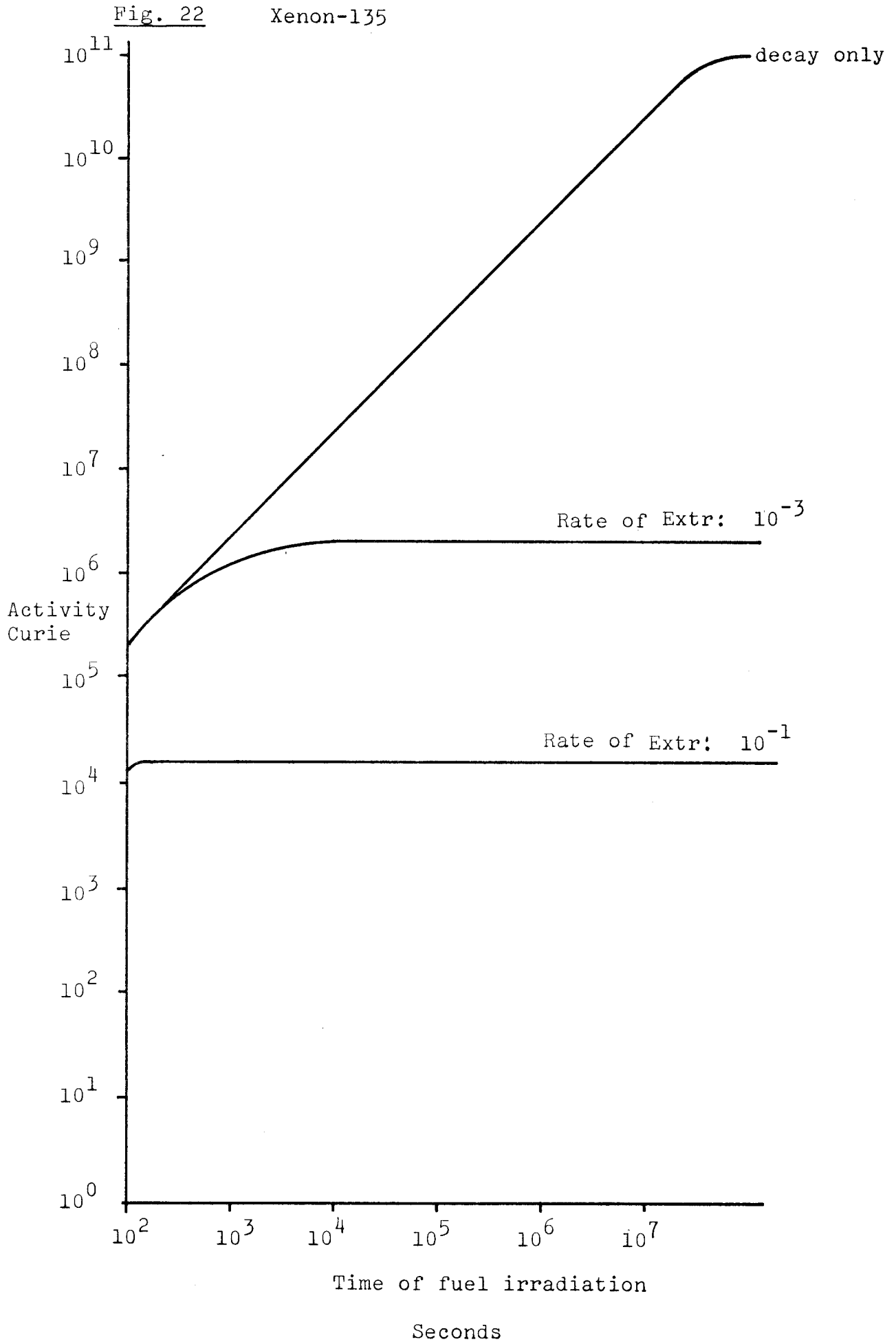

Fig. 21 Iodine-131







3. The extraction rate of Cs-137 is rather small and results in the diminishing of the caesium concentration by only 7 times when compared to the normal liquid fuel reprocessing having a time constant of  $10^6$  seconds or  $\approx 10$  days mean dwelling time of the liquid fuel in the reactor. In the solid fuel case the same amounts of Cs-137 are accumulated after approx 100 days that is  $\approx 3.5$  months dwell time in the core. A special feature of the molten chlorides fuel is that the vapour pressure of CsCl is much lower than  $\text{CsO}_2/\text{Cs}$  metal in solid oxide or carbide fuels, decreasing the amount of vapourised caesium in the case of a core accident. Another important point is that it appears possible to separate the caesium isotopes 135 and 137.
4. Further hazardous fission products such as Xe-133 and Xe-135 can also be effectively extracted and the steady state level is  $>100$  times lower than in the unextracted core.
5. The gas extraction rate influences also the oxygen extraction from the molten fuel which considerably improves the corrosion behaviour of metallic molybdenum and also the stability of the uranium and plutonium chlorides (Taube 1974).

#### Acknowledgements

The author thanks Mr. S. Padiyath for help in the writing and computation of the programme 'GASEX' and Mr. R. Stratton for polishing the English.

## Appendix I

Calculation of the gas stream rates.

The 2000 MW(th) reactor has a fission rate of about

$$2 \times 10^9 \text{ W} \times 3.1 \times 10^{10} \frac{\text{fiss/s}}{\text{W}} = \frac{1}{6.02 \times 10^{23}} \approx 100 \text{ } \mu\text{M Pu/s}$$

$$(\mu\text{M} = \text{micro Mol} = 6.02 \times 10^{23} \times 10^{-6} = 6.02 \times 10^{17} \text{ atoms})$$

The relative amounts of volatile nuclides is estimated very roughly here as 0.2, that is  $2 \times 20 \mu\text{M/s}$  of gaseous volatile elements. The volume of these elements at  $\sim 950^\circ\text{C}$  and  $\sim 10$  bars pressure is

$$40 \times 10^{-6} \text{ mol/s} \times \frac{22.2 \times 10^3 \text{ cm}^3}{\text{mol}} \times \frac{1253 \text{ K}}{273 \text{ K}} \times \frac{1}{10} \approx 0.4 \text{ cm}^3/\text{s}$$

This amount of  $0.4 \text{ cm}^3/\text{s}$  must be removed from the core by means of continuous gas extraction. If we postulate a helium stream (with probably 1 mol % of hydrogen) of  $4 \text{ cm}^3/\text{s}$  then it seems the volatile elements can be removed. The assumed dwelling time of the gas bubbles in the core is 10 to 1000 s. The volume of the gaseous phase in the core is from 40 to 4000  $\text{cm}^3$ .

The total volume of fuel in the core equals

$$8.75 \frac{\text{m}^3}{\text{core}} \times 0.386 \text{ fuel fraction} = 3.377 \text{ m}^3$$

The volume of gas bubbles given above equals from  $10^{-5}$  to  $10^{-3}$  of the fuel volume. This should not give rise to problems of criticality particularly in the steady state.

