



# XAVIER NX CONNECTOR

REVISIONS			
REV	DESCRIPTION	DATE	APPROVED

D  
C  
B  
A

D  
C  
B  
A

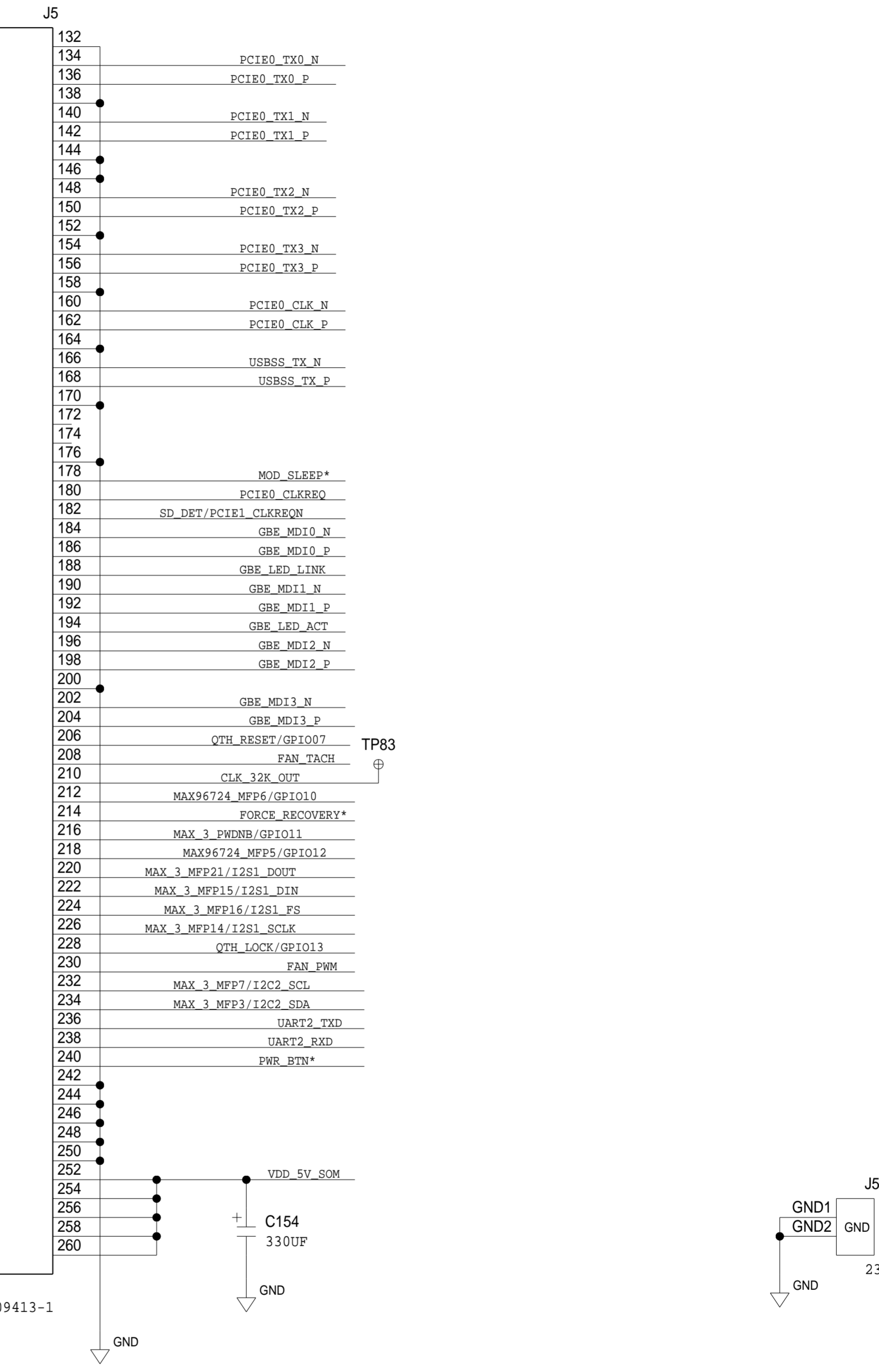
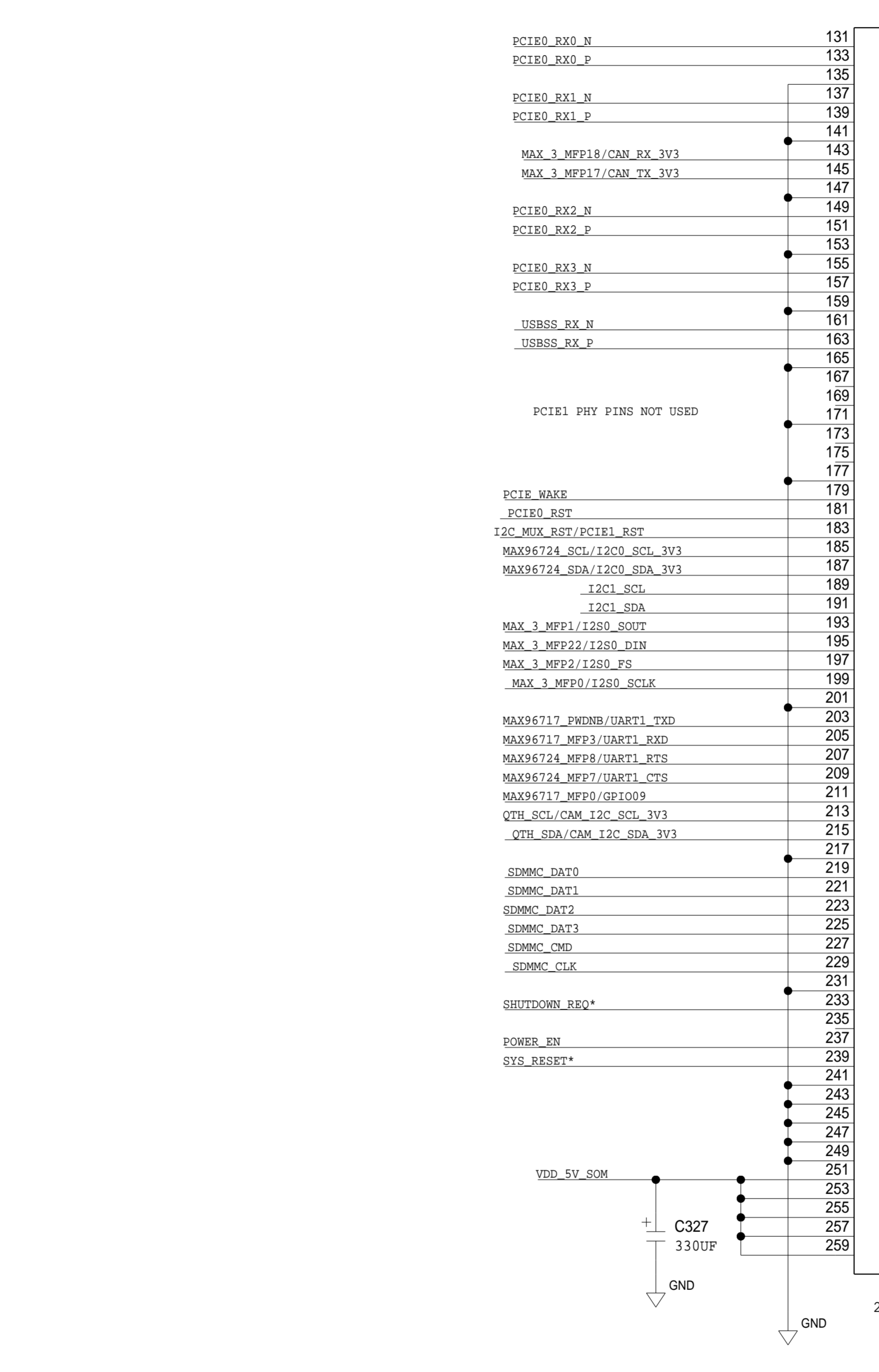
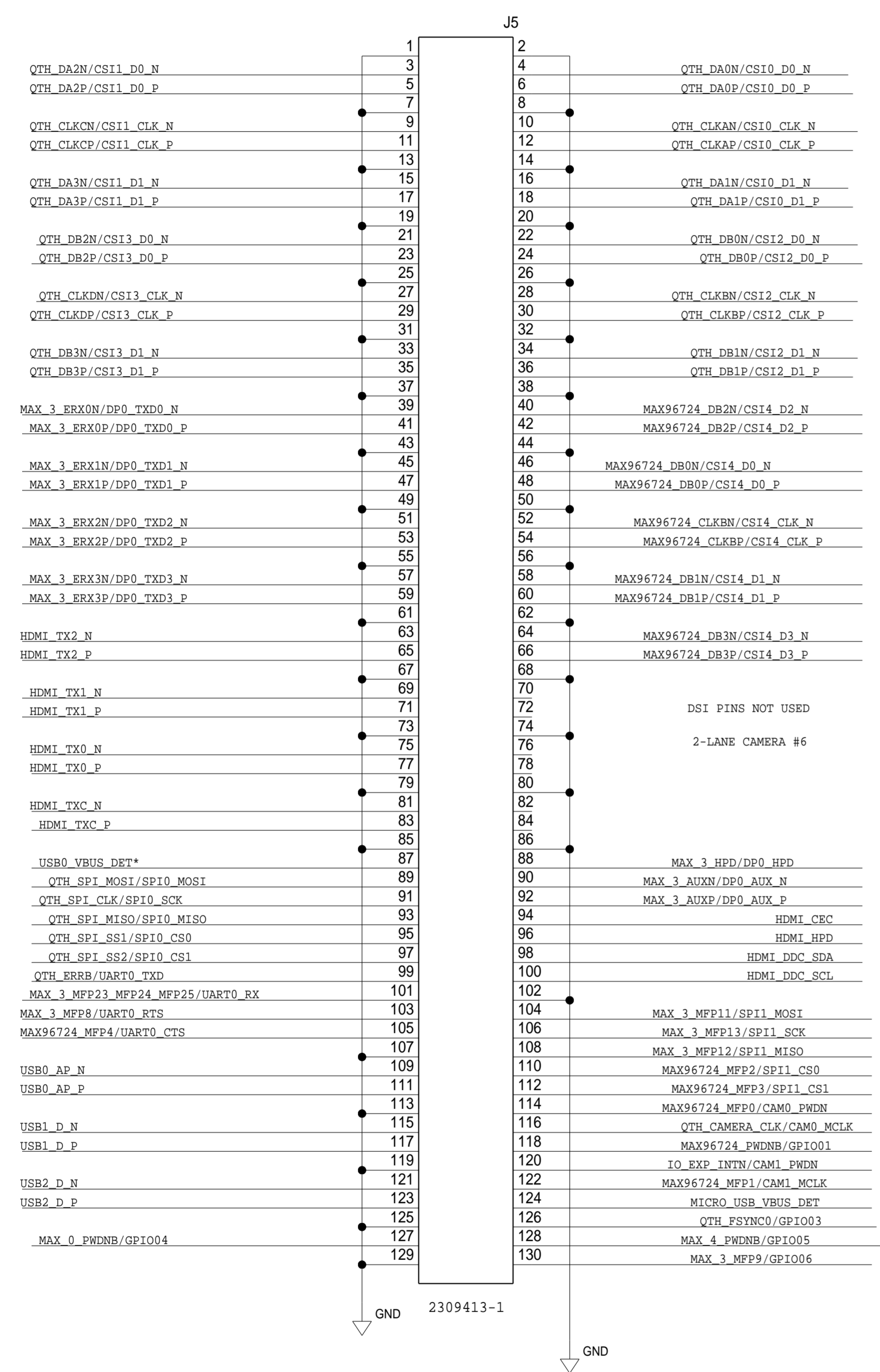

	<b>SCHEMATIC</b>		
	HW TYPE : Customer Evaluation Z Product(s): GMSL Camera : GMSL MIPI CSI-2 Deserializers		
DESIGN VIEW <DESIGN_VIEW>	DRAWING NO. 02_074767	REV B	
PTD ENGINEER A. POP	SIZE D	SCALE 1:1	SHEET 2 OF 17

REVISIONS			
REV	DESCRIPTION	DATE	APPROVED

### GMSL INPUTS

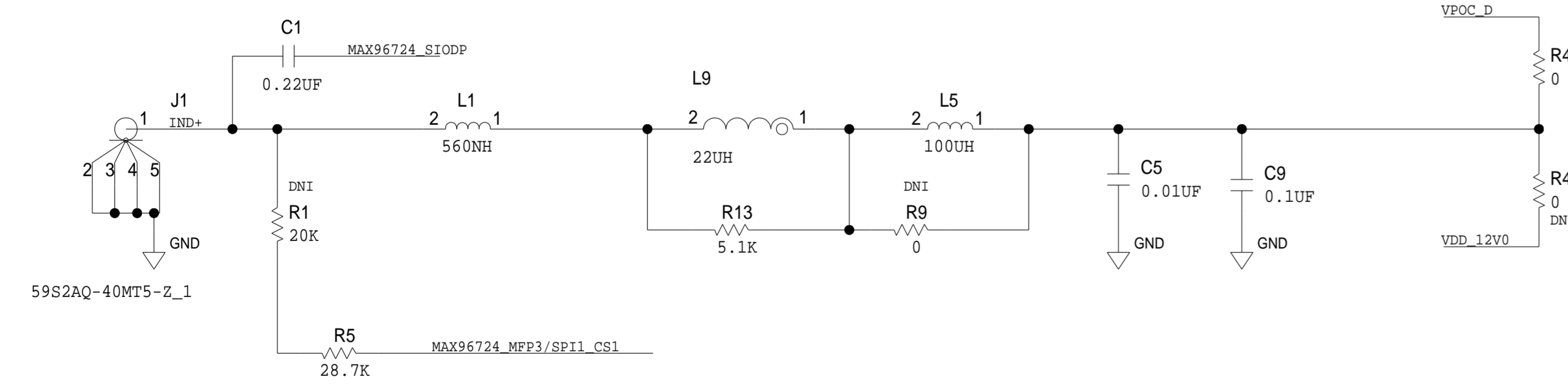
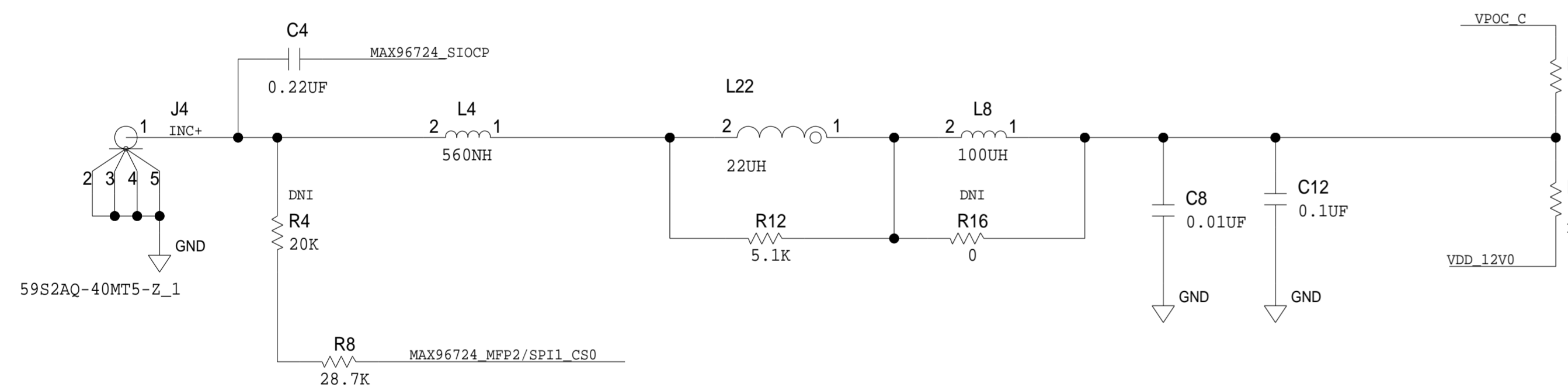
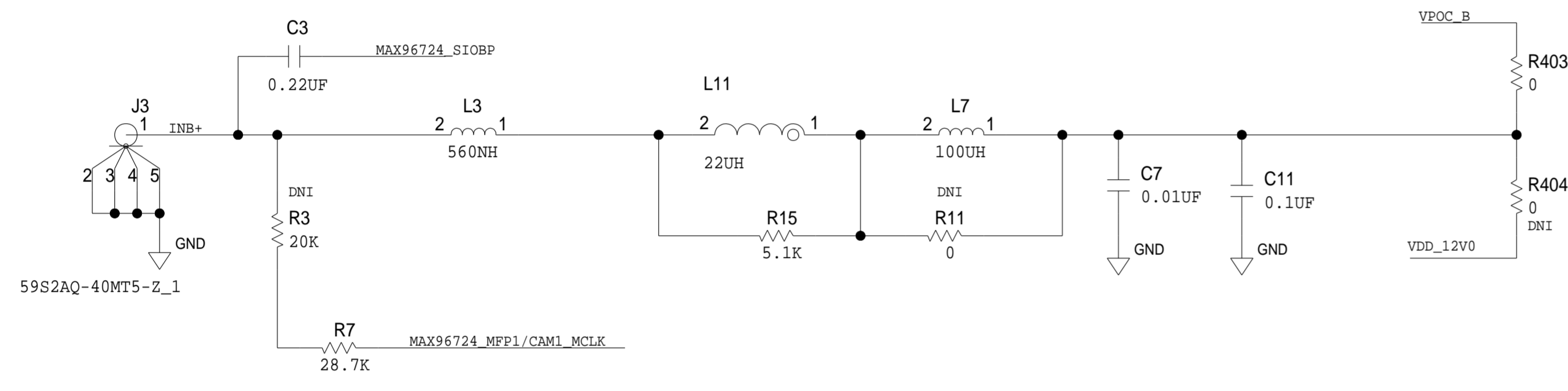
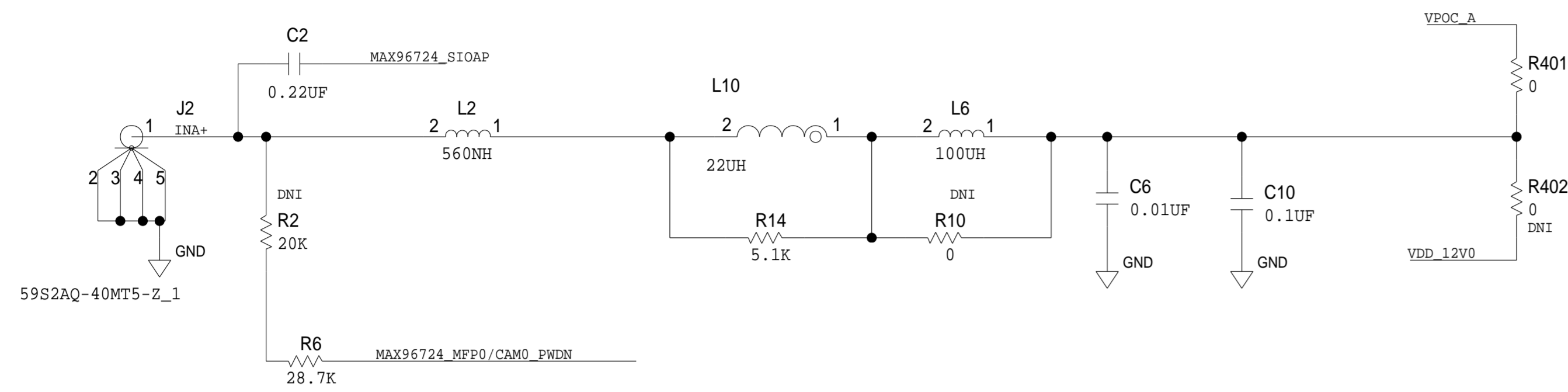

### CSI INPUTS- SAMTEC QTH

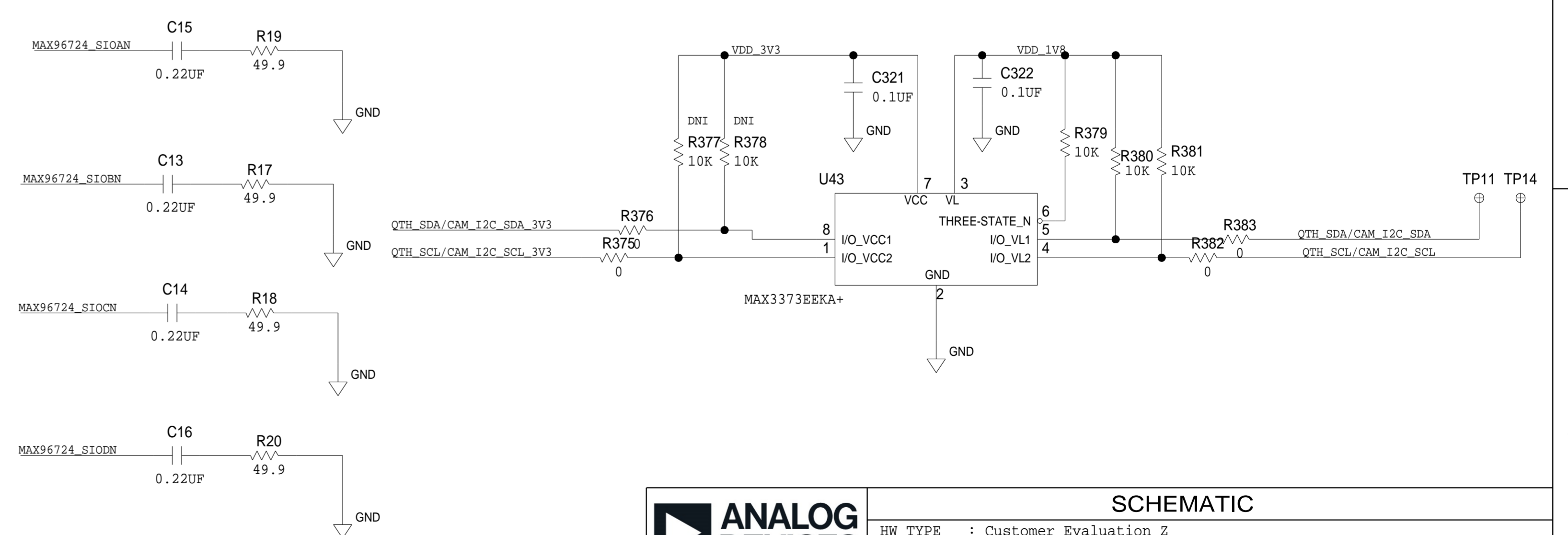
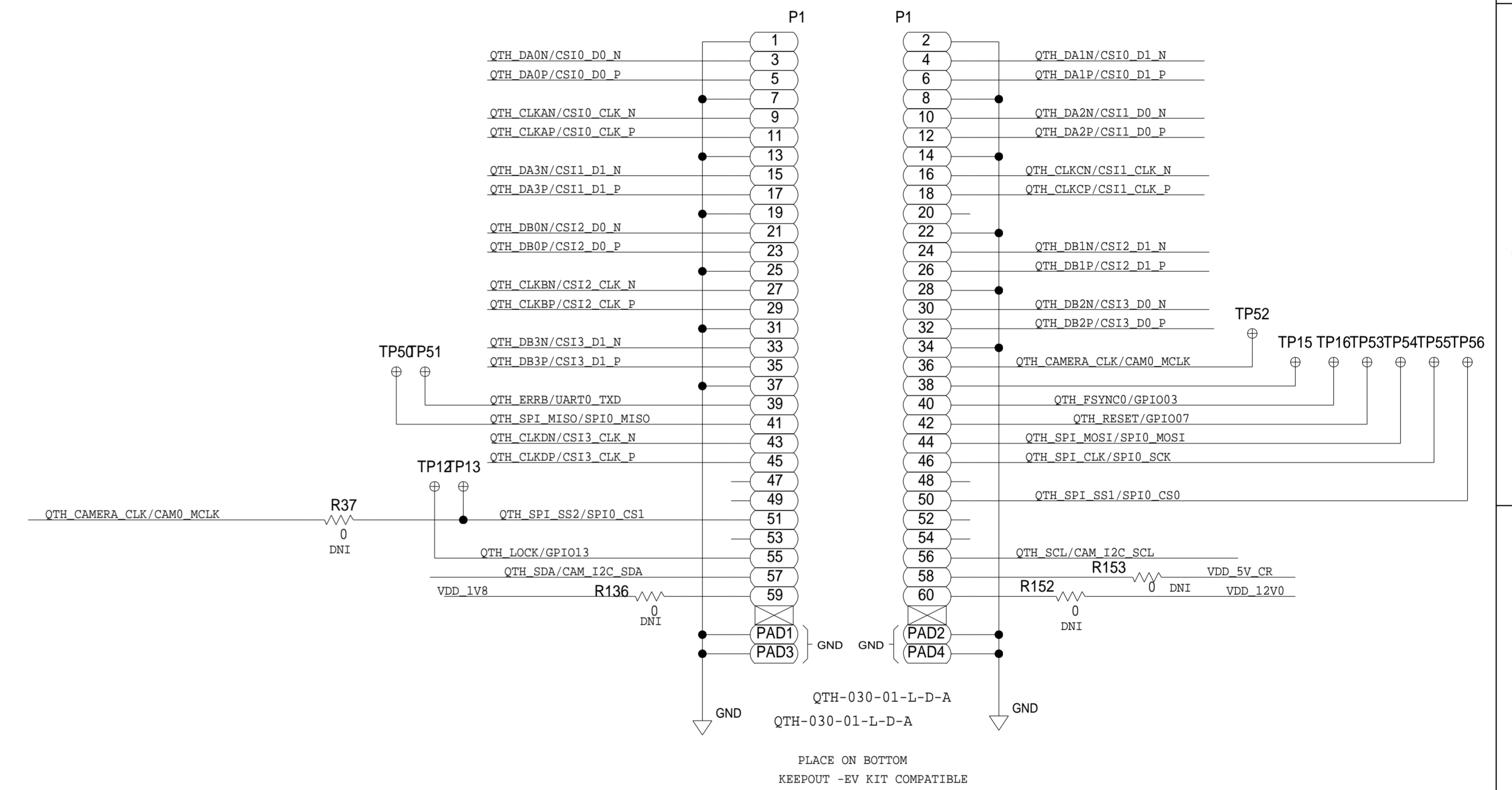

	<b>SCHEMATIC</b>		
	HW TYPE : Customer Evaluation Z Product(s) : GMSL Camera : GMSL MIPI CSI-2 Deserializers		
DESIGN VIEW <DESIGN_VIEW>	DRAWING NO. 02_074767	REV B	
PTD ENGINEER A. POP	SIZE D	SCALE 1:1	SHEET 3 OF 17

QUAD TUNNELING GMSL2/1 TO CSI-2 DESERIALIZER

REVISIONS			
REV	DESCRIPTION	DATE	APPROVED

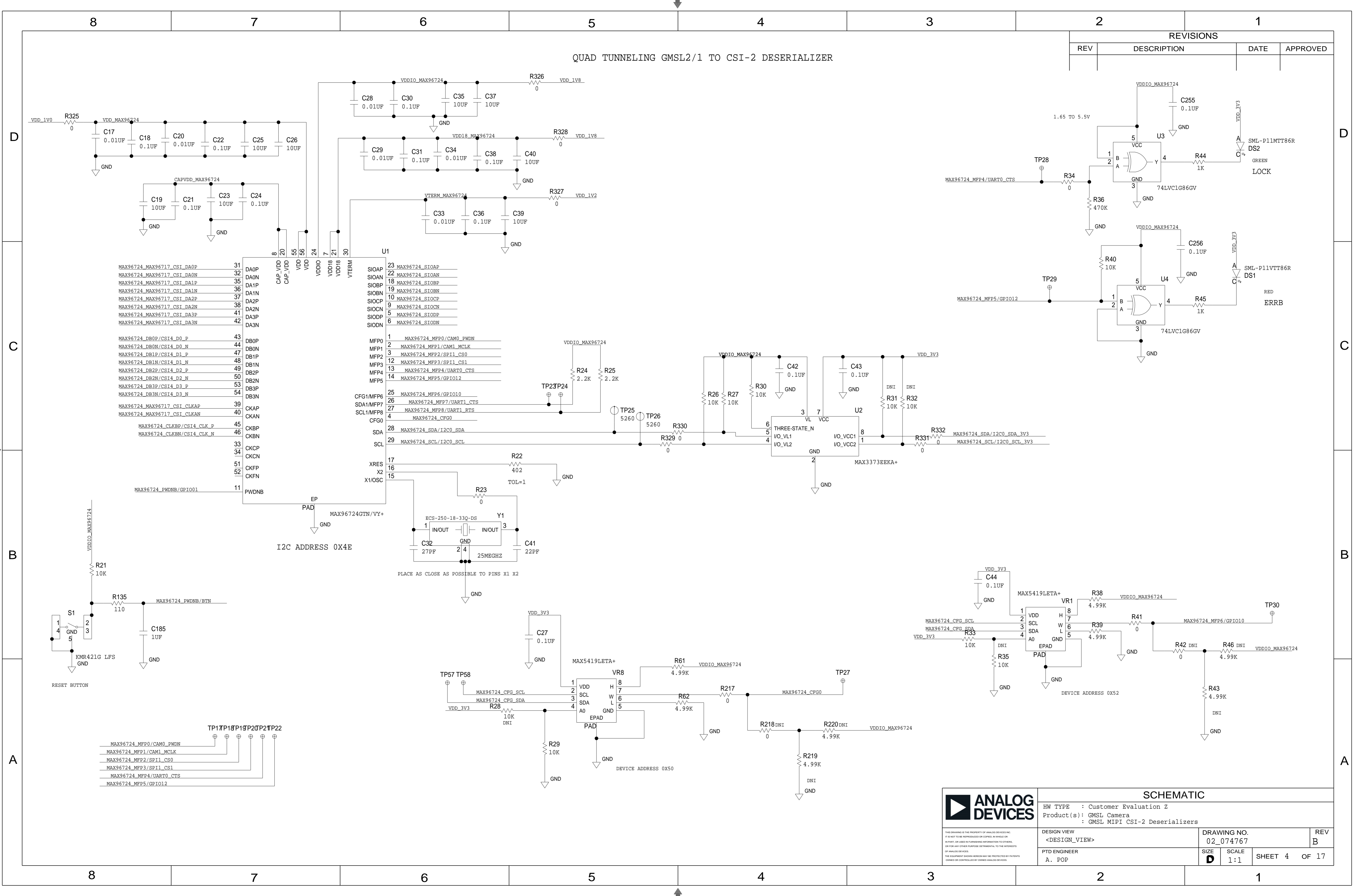

MAX96724_MAX96717_CSI_DA0P	31	DA0P	MAX96724_SIOAP	23
MAX96724_MAX96717_CSI_DA0N	32	DA0N	MAX96724_SIOAN	22
MAX96724_MAX96717_CSI_DA1P	35	DA1P	MAX96724_SIOBP	18
MAX96724_MAX96717_CSI_DA1N	36	DA1N	MAX96724_SIOBN	19
MAX96724_MAX96717_CSI_DA2P	37	DA2P	MAX96724_SIOCP	10
MAX96724_MAX96717_CSI_DA2N	38	DA2N	MAX96724_SIOCN	9
MAX96724_MAX96717_CSI_DA3P	41	DA3P	MAX96724_SIODP	5
MAX96724_MAX96717_CSI_DA3N	42	DA3N	MAX96724_SIODN	6
MAX96724_DB0P/CSI4_D0_P	43	DB0P	MAX96724_MFP0/CAM0_PWDN	1
MAX96724_DB0N/CSI4_D0_N	44	DB0N	MAX96724_MFP1/CAM1_MCLK	2
MAX96724_DB1P/CSI4_D1_P	47	DB1P	MAX96724_MFP2/SP11_CS0	3
MAX96724_DB1N/CSI4_D1_N	48	DB1N	MAX96724_MFP3/SP11_CS1	12
MAX96724_DB2P/CSI4_D2_P	49	DB2P	MAX96724_MFP4/UART0_CTS	13
MAX96724_DB2N/CSI4_D2_N	50	DB2N	MAX96724_MFP5/GPI012	14
MAX96724_DB3P/CSI4_D3_P	53	DB3P	MAX96724_MFP6/GPI010	25
MAX96724_DB3N/CSI4_D3_N	54	DB3N	MAX96724_MFP7/UART1_CTS	26
MAX96724_MAX96717_CSI_CLKAP	39	CKAP	MAX96724_MFP8/UART1_RTS	27
MAX96724_MAX96717_CSI_CLKAN	40	CKAN	MAX96724_CFG0	4
MAX96724_CLKBP/CSI4_CLK_P	45	CKBP	MAX96724_SDA/I2C0_SDA	28
MAX96724_CLKBN/CSI4_CLK_N	46	CKBN	MAX96724_SCL/I2C0_SCL	29
MAX96724_PWDNB/GPI001	11	PWDNB	MAX96724_CFG0	4
MAX96724_XRES	17	XRES	MAX96724_CFG0	4
MAX96724_X2	16	X2	MAX96724_CFG0	4
MAX96724_X1/OSC	15	X1/OSC	MAX96724_CFG0	4

- MAX96724\_MFP0/CAM0\_PWDN
- MAX96724\_MFP1/CAM1\_MCLK
- MAX96724\_MFP2/SP11\_CS0
- MAX96724\_MFP3/SP11\_CS1
- MAX96724\_MFP4/UART0\_CTS
- MAX96724\_MFP5/GPI012

	<b>SCHEMATIC</b>		
	HW TYPE : Customer Evaluation Z Product(s) : GMSL Camera : GMSL MIPI CSI-2 Deserializers		
DESIGN VIEW <DESIGN_VIEW>	DRAWING NO. 02_074767	REV B	
PTD ENGINEER A. POP	SIZE D	SCALE 1:1	SHEET 4 OF 17

REVISIONS			
REV	DESCRIPTION	DATE	APPROVED

### CSI-2 TO GMSL2 SERIALIZER

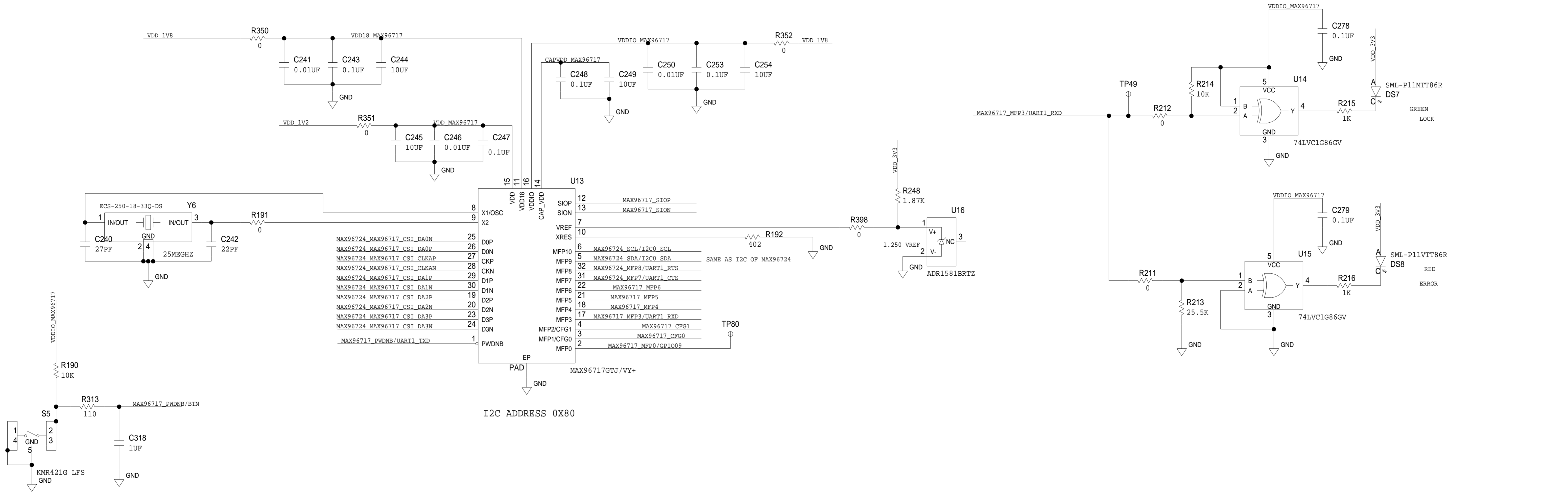

### FAKRA GSML OUTPUT OF MAX96717

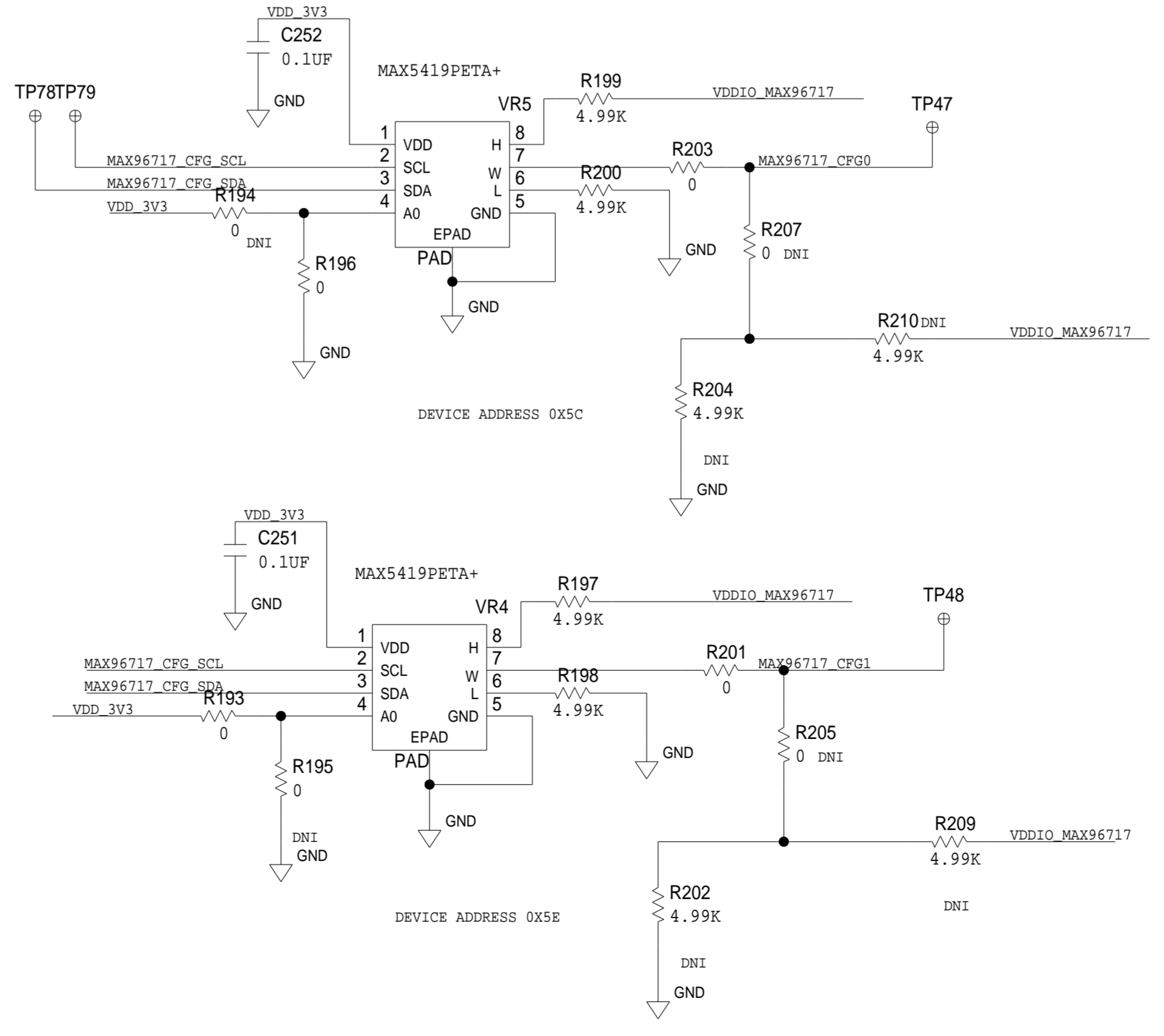
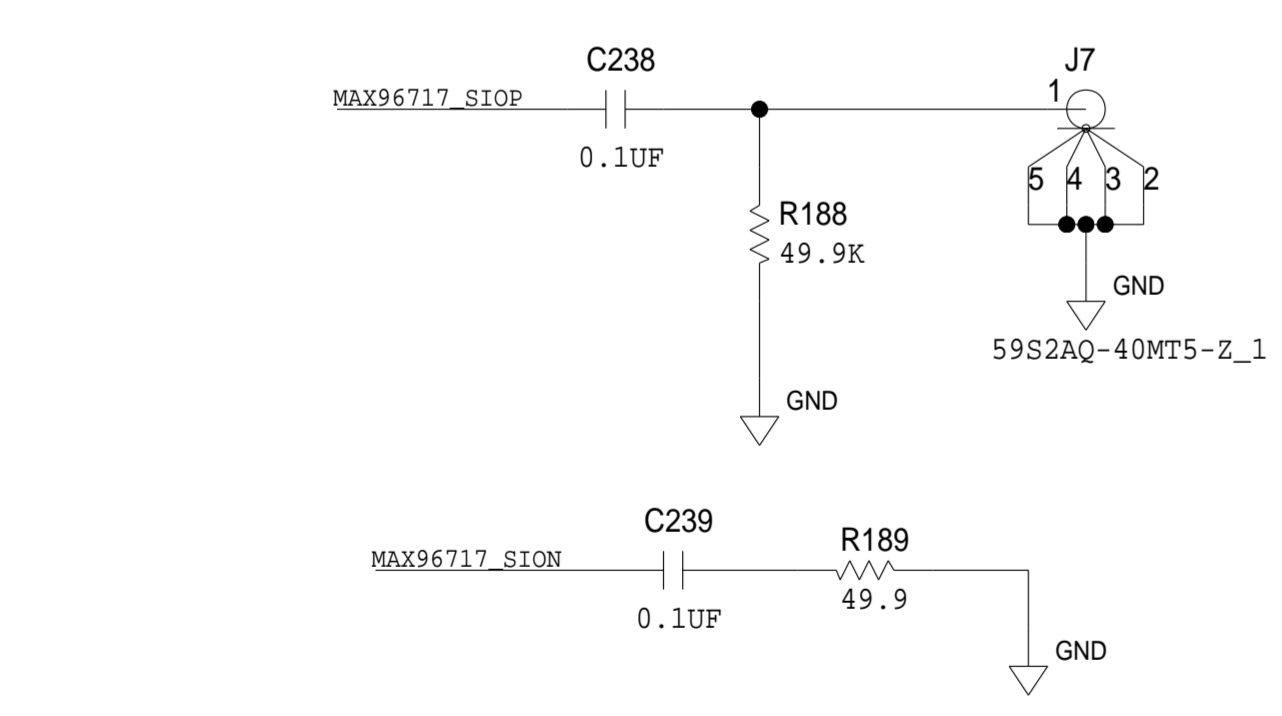

	<b>SCHEMATIC</b>		
	HW TYPE : Customer Evaluation Z Product(s) : GMSL Camera : GMSL MIPI CSI-2 Deserializers		
DESIGN VIEW <DESIGN_VIEW>	DRAWING NO. 02_074767	REV B	
PTD ENGINEER A. POP	SIZE D	SCALE 1:1	SHEET 5 OF 17

REVISIONS			
REV	DESCRIPTION	DATE	APPROVED

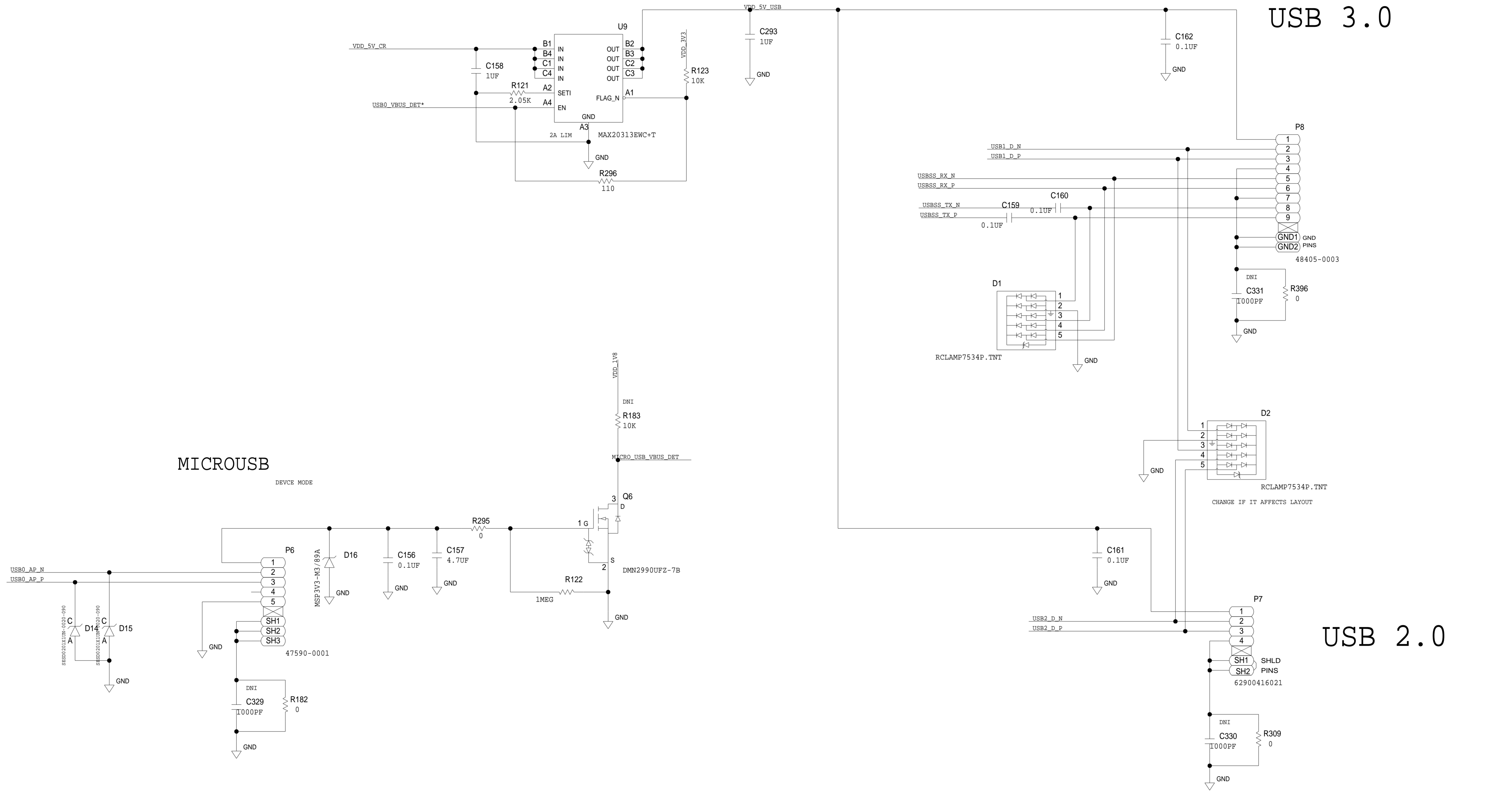

USB 3.0

MICROUSB

USB 2.0

	<b>SCHEMATIC</b>		
	HW TYPE : Customer Evaluation Z Product(s): GMSL Camera : GMSL MIPI CSI-2 Deserializers		
DESIGN VIEW <DESIGN_VIEW>	DRAWING NO. 02_074767	REV B	
PTD ENGINEER A. POP	SIZE D	SCALE 1:1	SHEET 6 OF 17

REVISIONS			
REV	DESCRIPTION	DATE	APPROVED

# M.2 KEY M

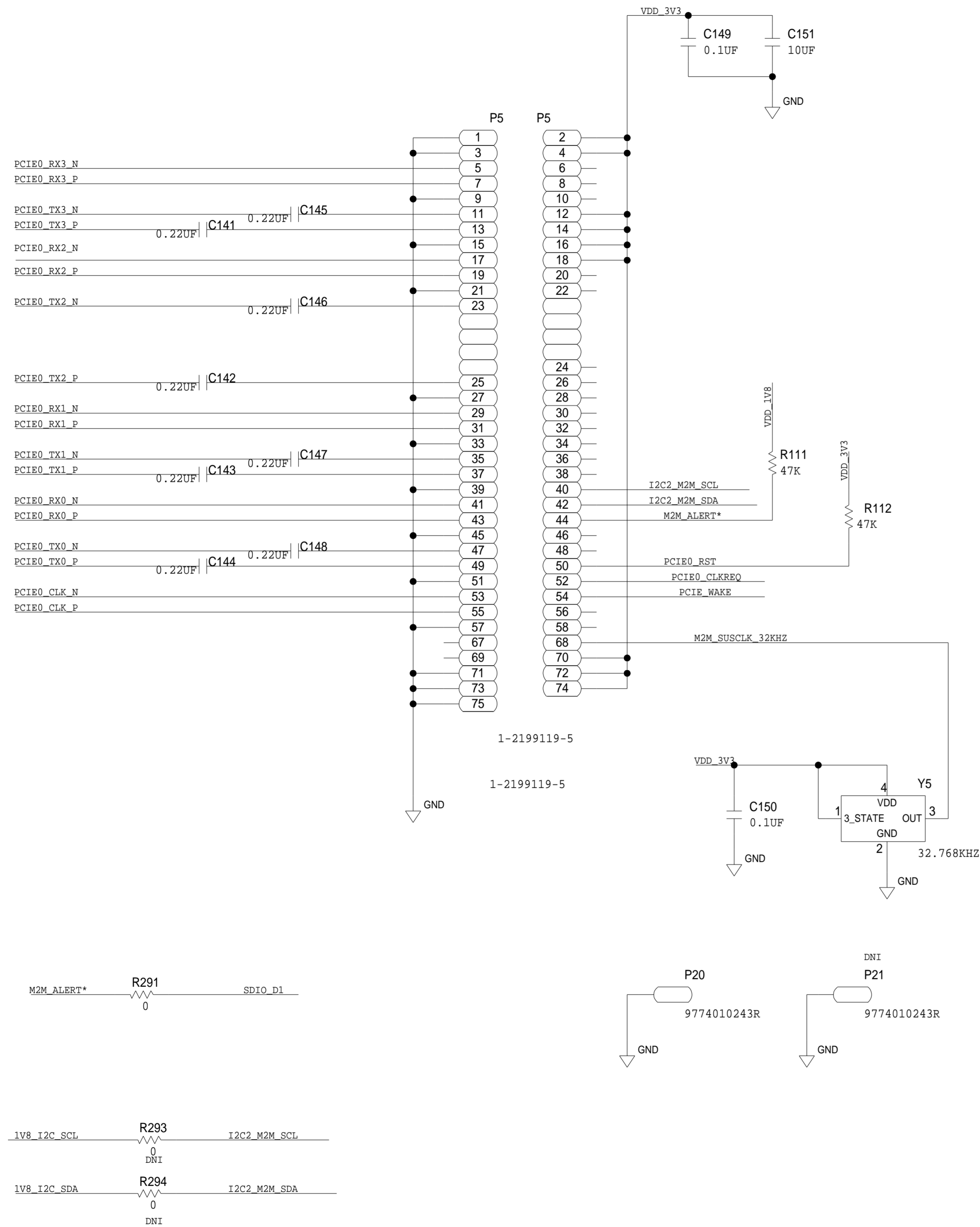

# EHTERNET RJ45

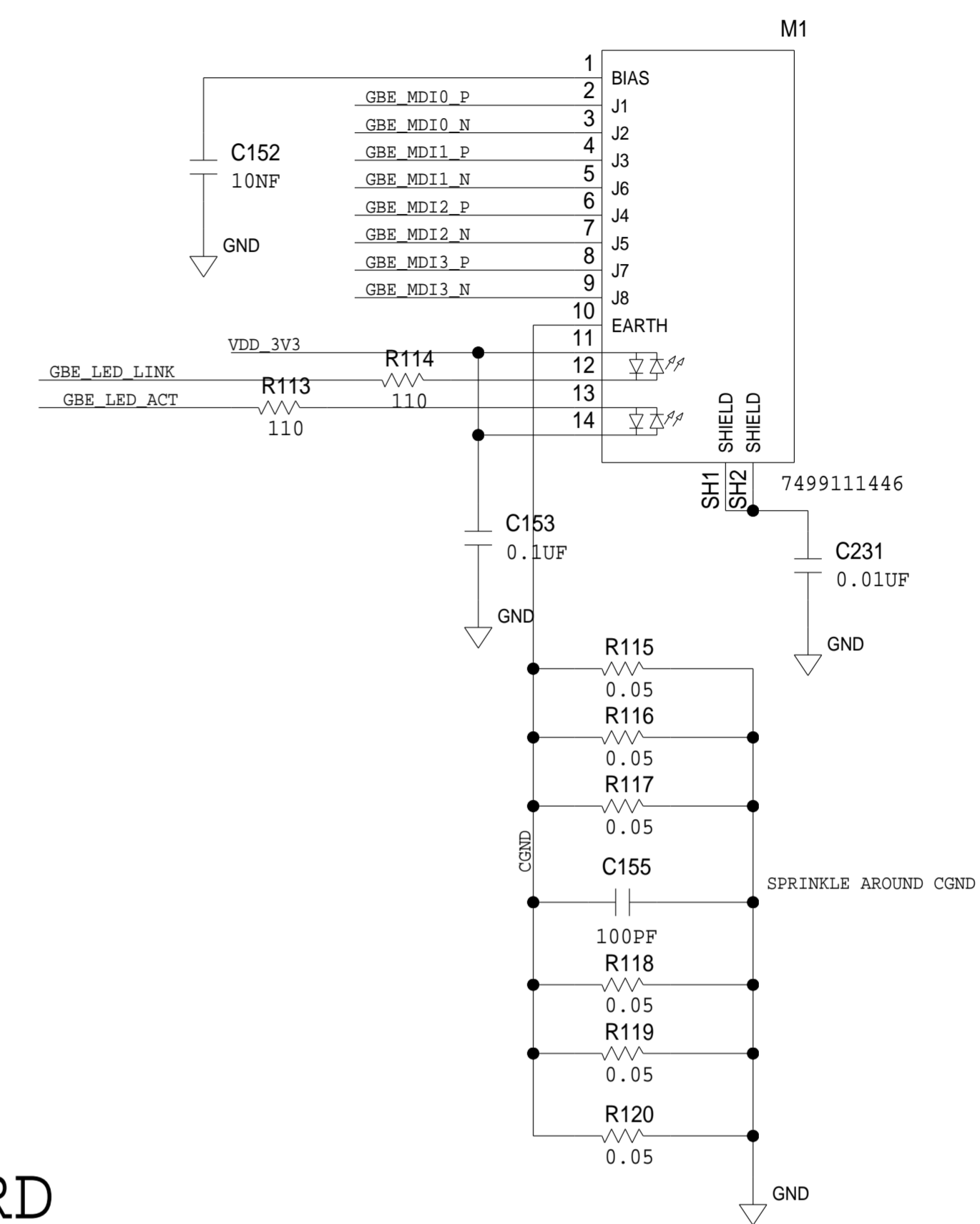

# MICRO SD CARD

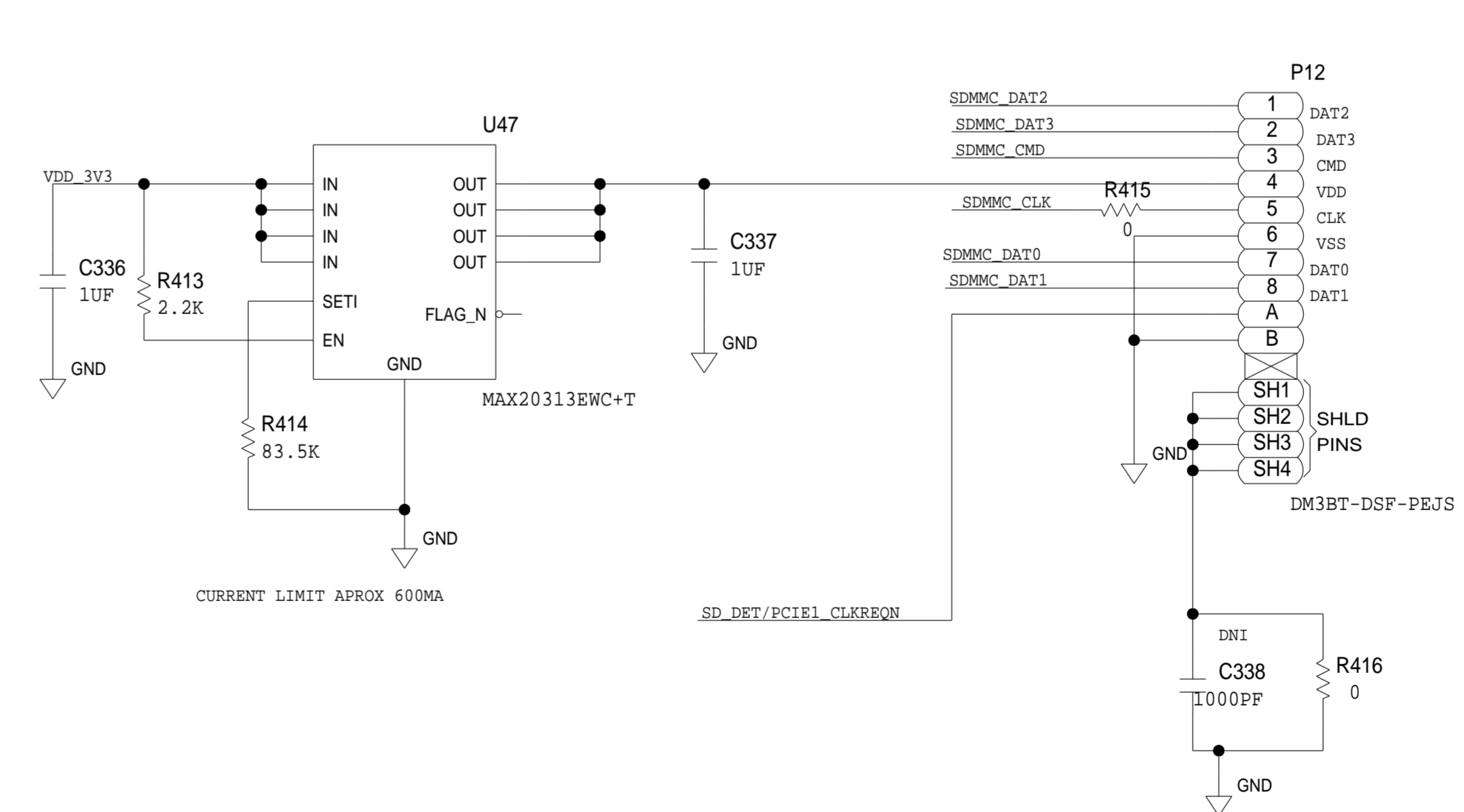

	<b>SCHEMATIC</b>		
	HW TYPE : Customer Evaluation Z Product(s): GMSL Camera : GMSL MIPI CSI-2 Deserializers		
DESIGN VIEW <DESIGN_VIEW>	DRAWING NO. 02_074767	REV B	
PTD ENGINEER A. POP	SIZE D	SCALE 1:1	SHEET 7 OF 17

# HDMI OUT

REVISIONS			
REV	DESCRIPTION	DATE	APPROVED

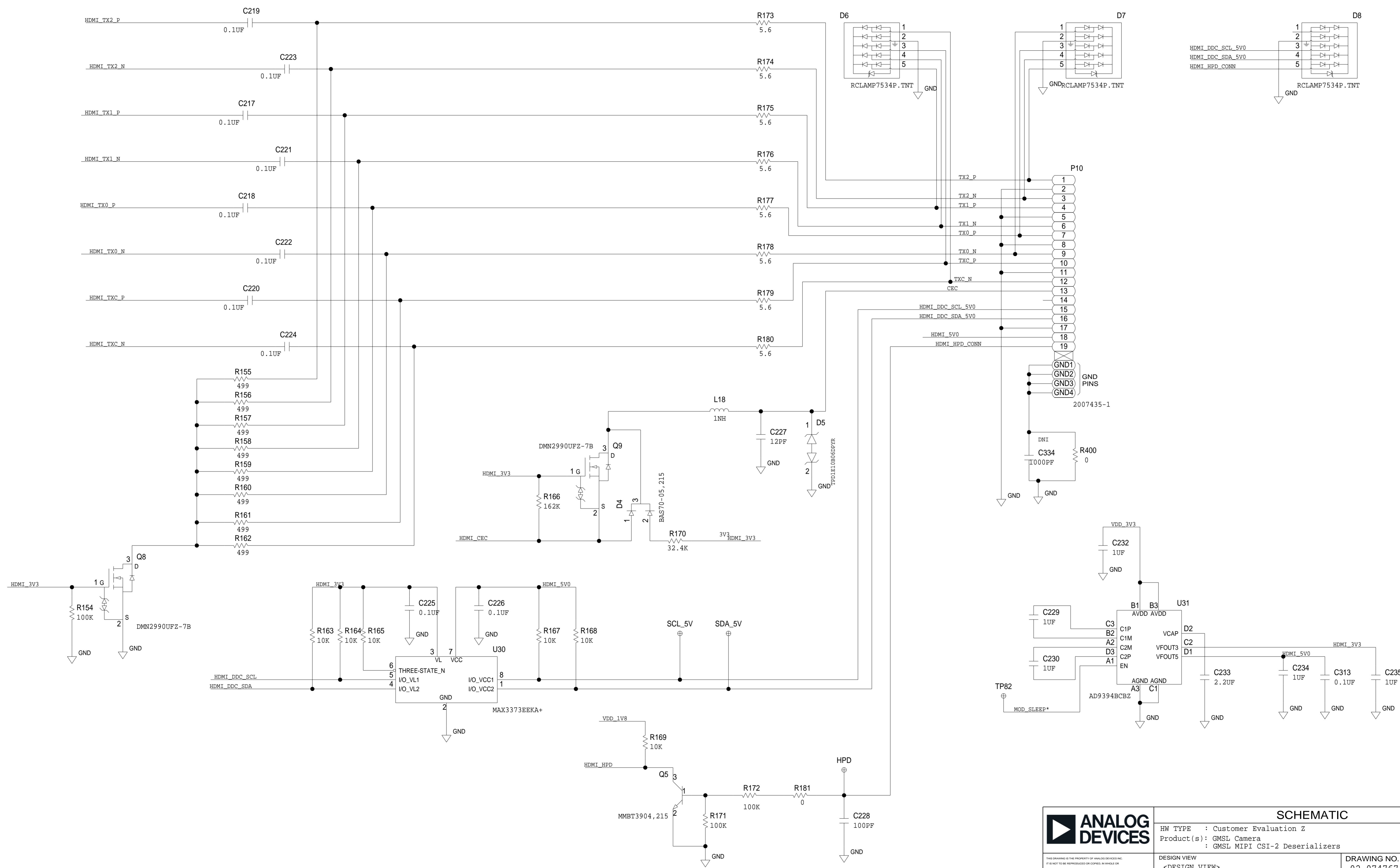

	<b>SCHEMATIC</b>		
	HW TYPE : Customer Evaluation Z Product(s) : GMSL Camera : GMSL MIPI CSI-2 Deserializers		
DESIGN VIEW <DESIGN_VIEW>	DRAWING NO. 02_074767	REV B	
PTD ENGINEER A. POP	SIZE D	SCALE 1:1	SHEET 8 OF 17

REVISIONS			
REV	DESCRIPTION	DATE	APPROVED

### FAN HEADER

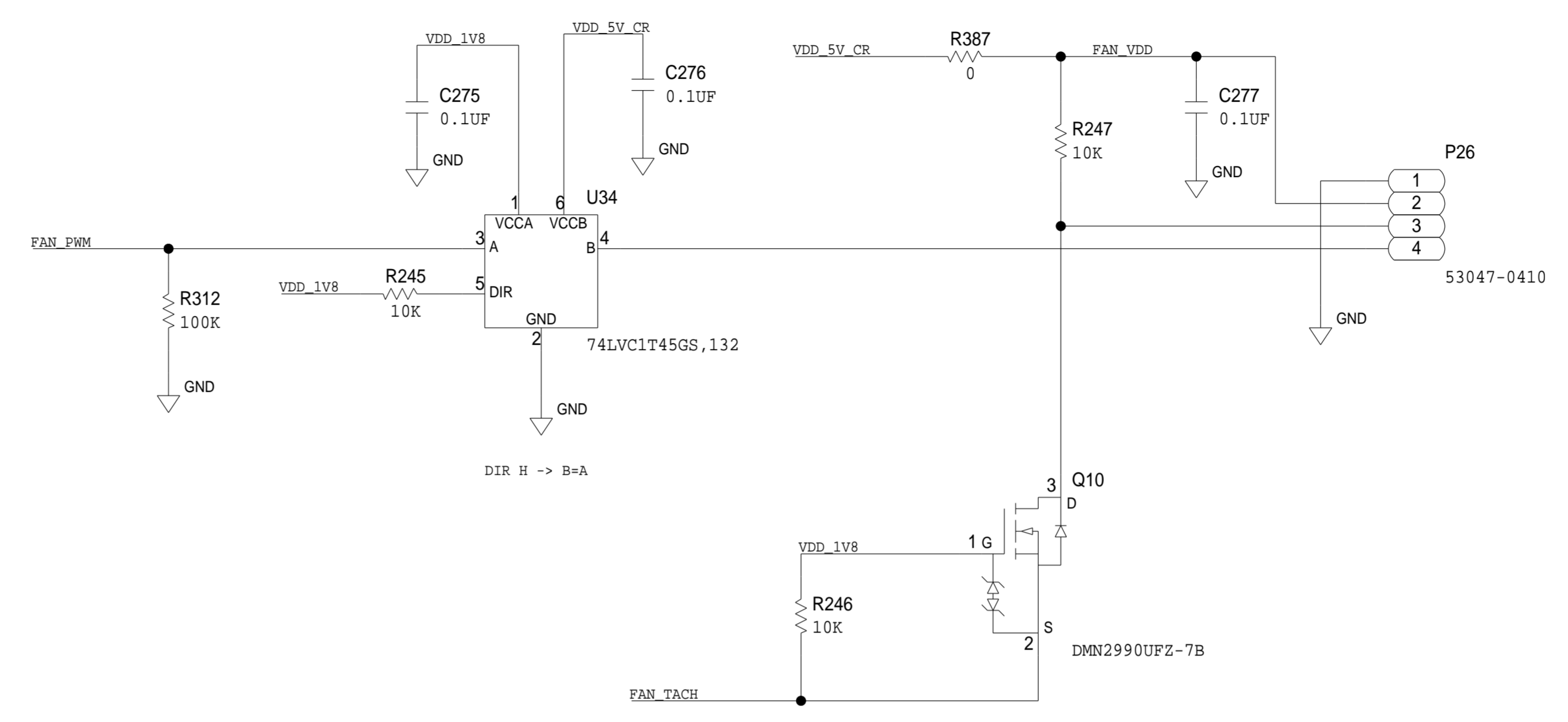

### EEPROM

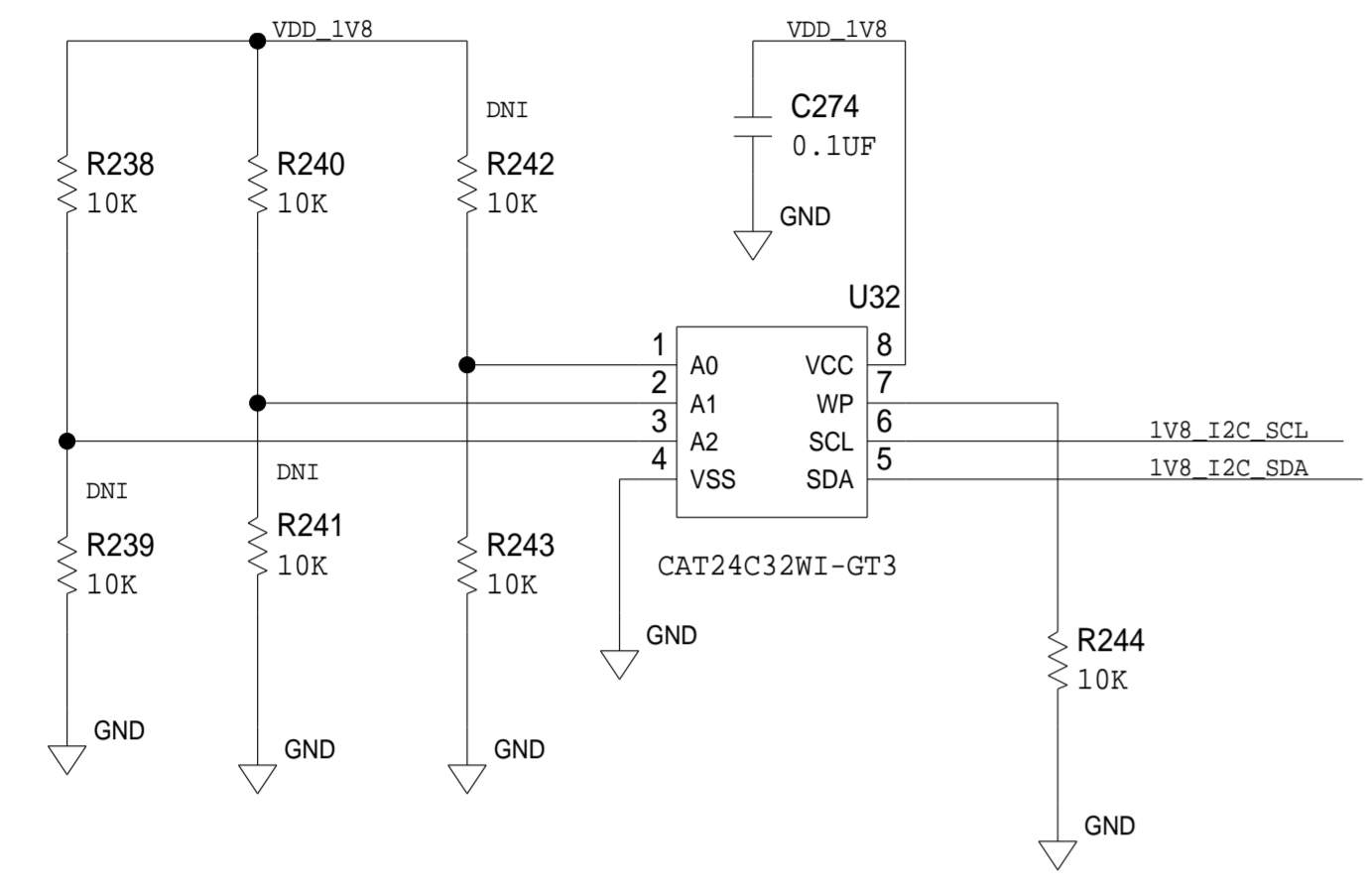

### USB SERIAL DEBUG

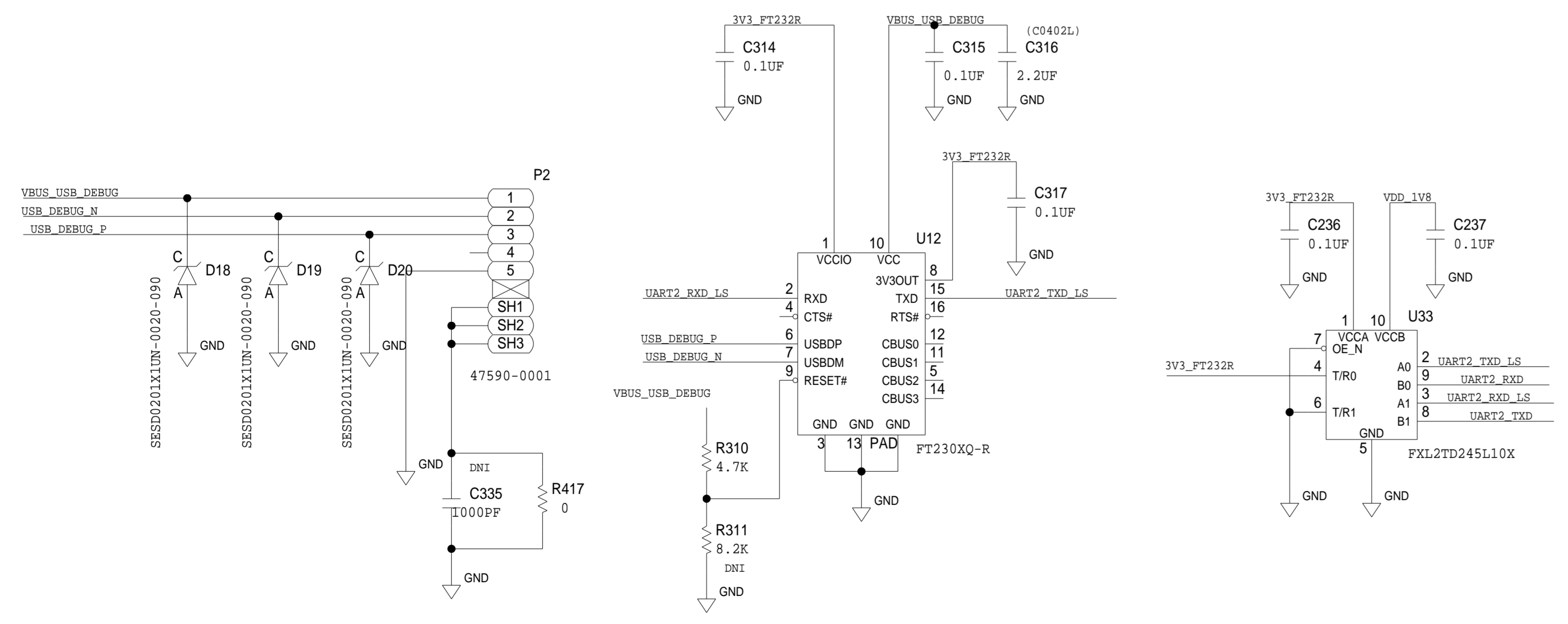

### RESET HEADER

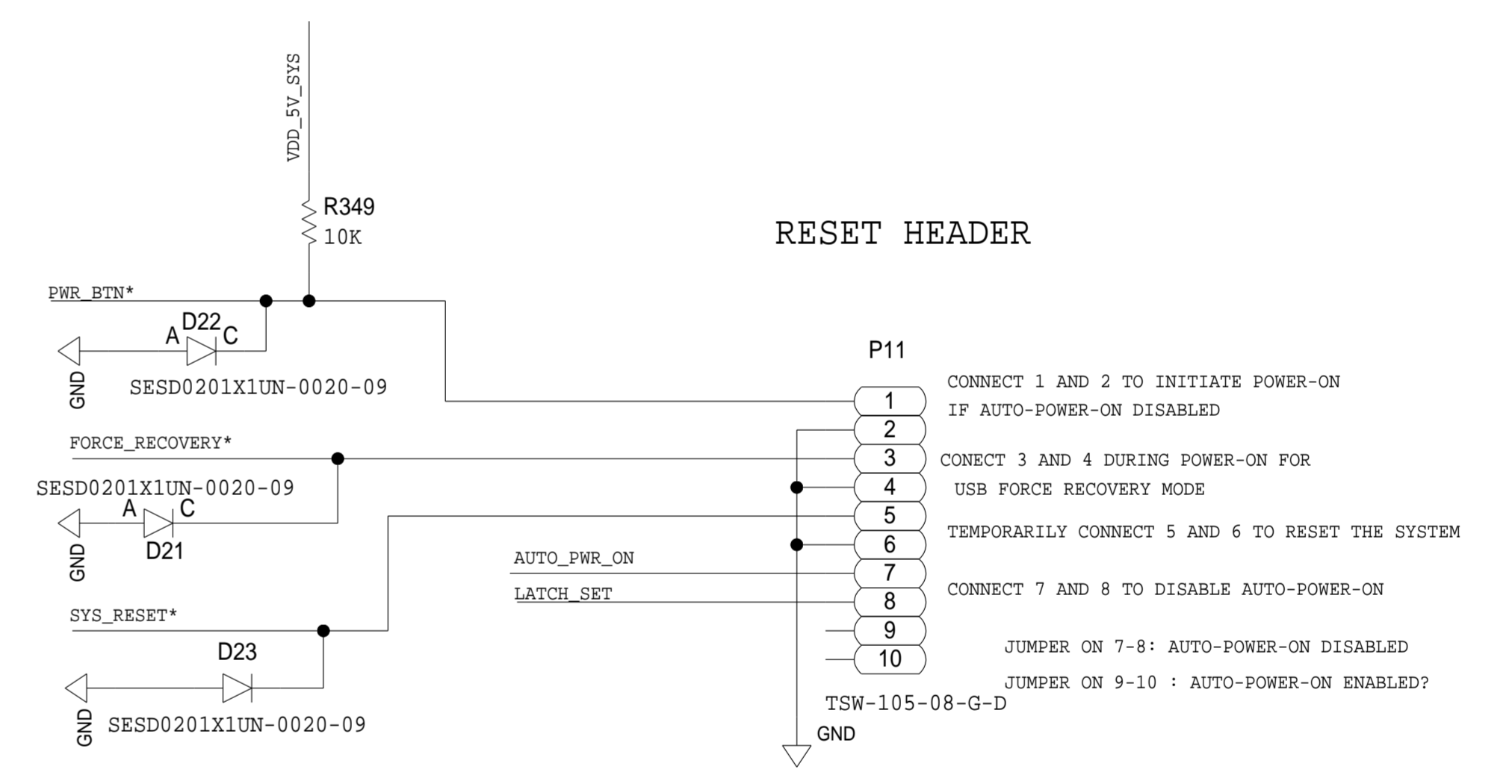

ANALOG DEVICES		SCHEMATIC			
HW TYPE : Customer Evaluation Z		Product(s) : GMSL Camera			
DESIGN VIEW : <DESIGN_VIEW>		DRAWING NO. : 02_074767		REV : B	
PTD ENGINEER : A. POP		SIZE : D	SCALE : 1:1	SHEET 9 OF 17	

# I2C MUX

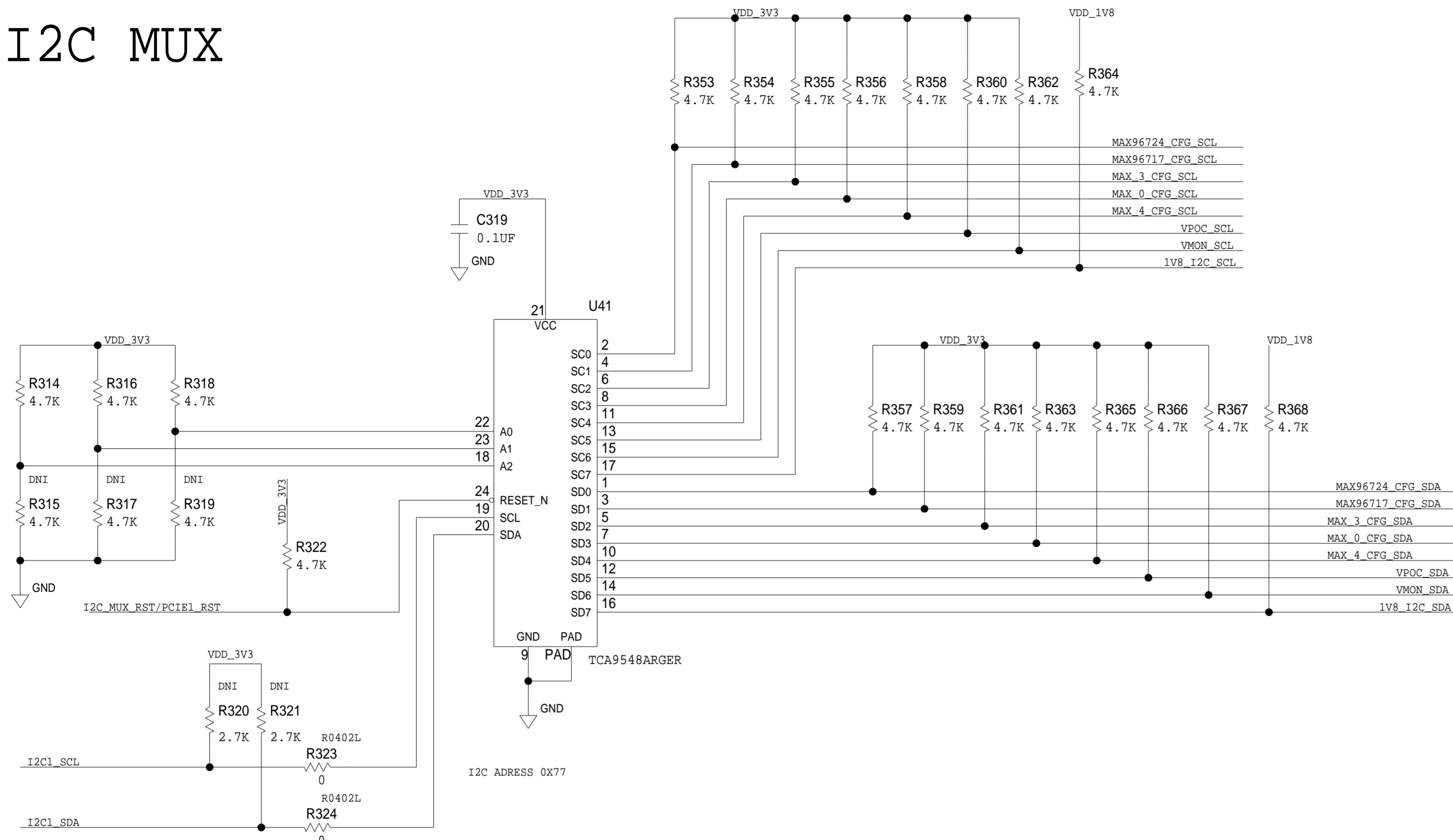

REVISIONS			
REV	DESCRIPTION	DATE	APPROVED

# I/O EXPANSION

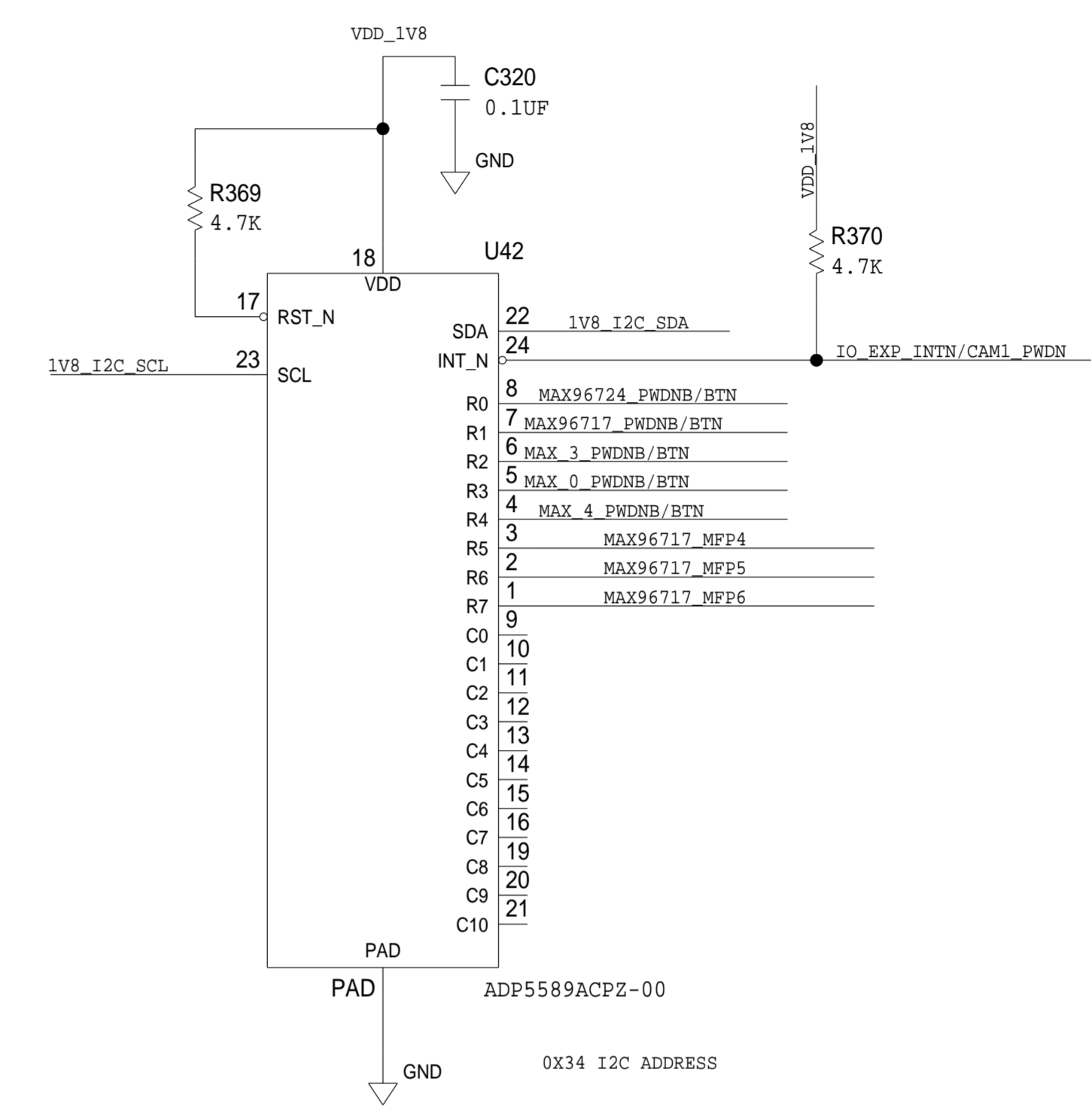

# VOLTAGE MONITOR

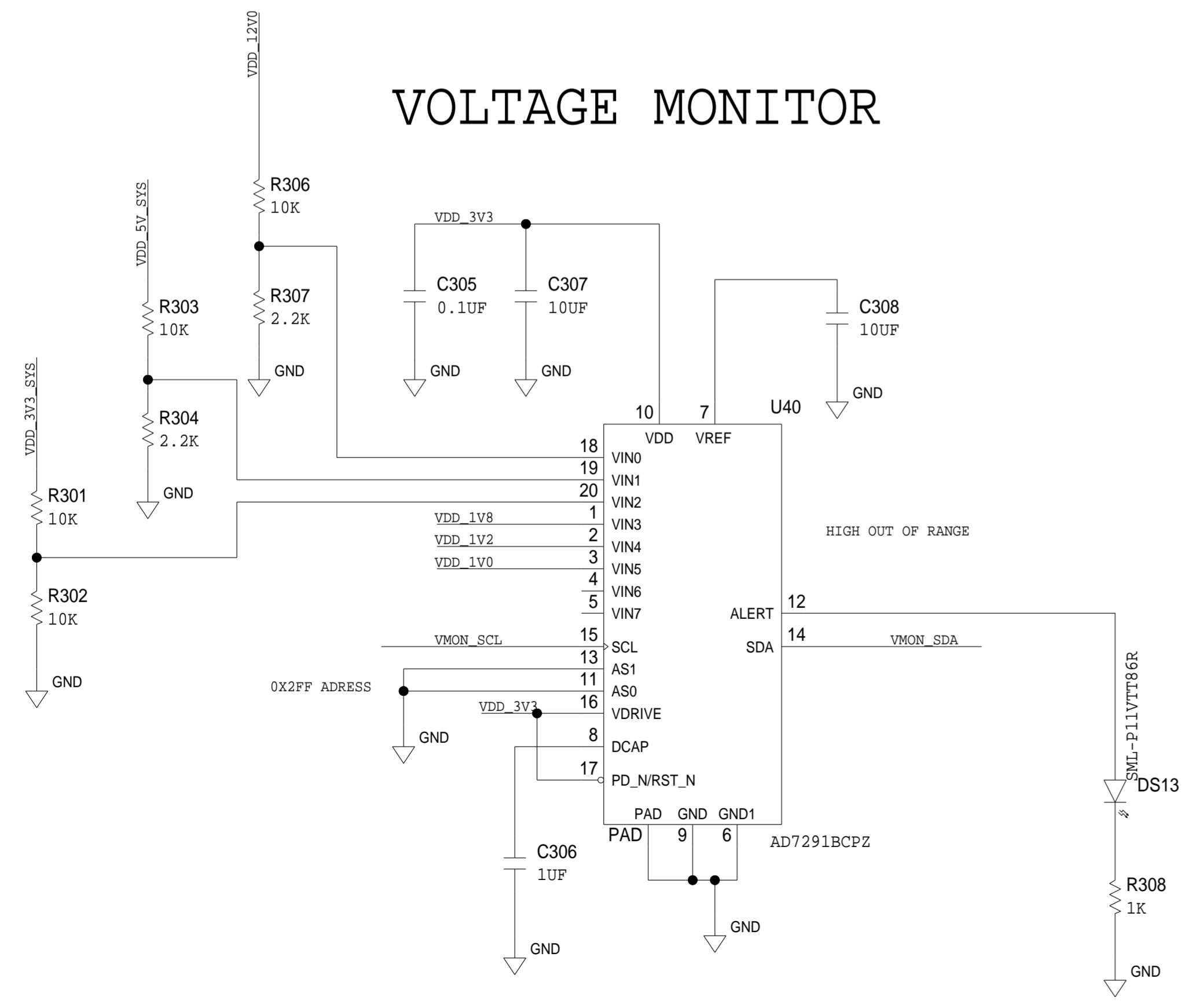

	<b>SCHEMATIC</b>		
	HW TYPE : Customer Evaluation Z Product(s) : GMSL Camera : GMSL MIPI CSI-2 Deserializers		
DESIGN VIEW <DESIGN_VIEW>	DRAWING NO. 02_074767	REV B	
PTD ENGINEER A. POP	SIZE D	SCALE 1:1	SHEET 10 OF 17



REVISIONS			
REV	DESCRIPTION	DATE	APPROVED

# 5V SUPPLY

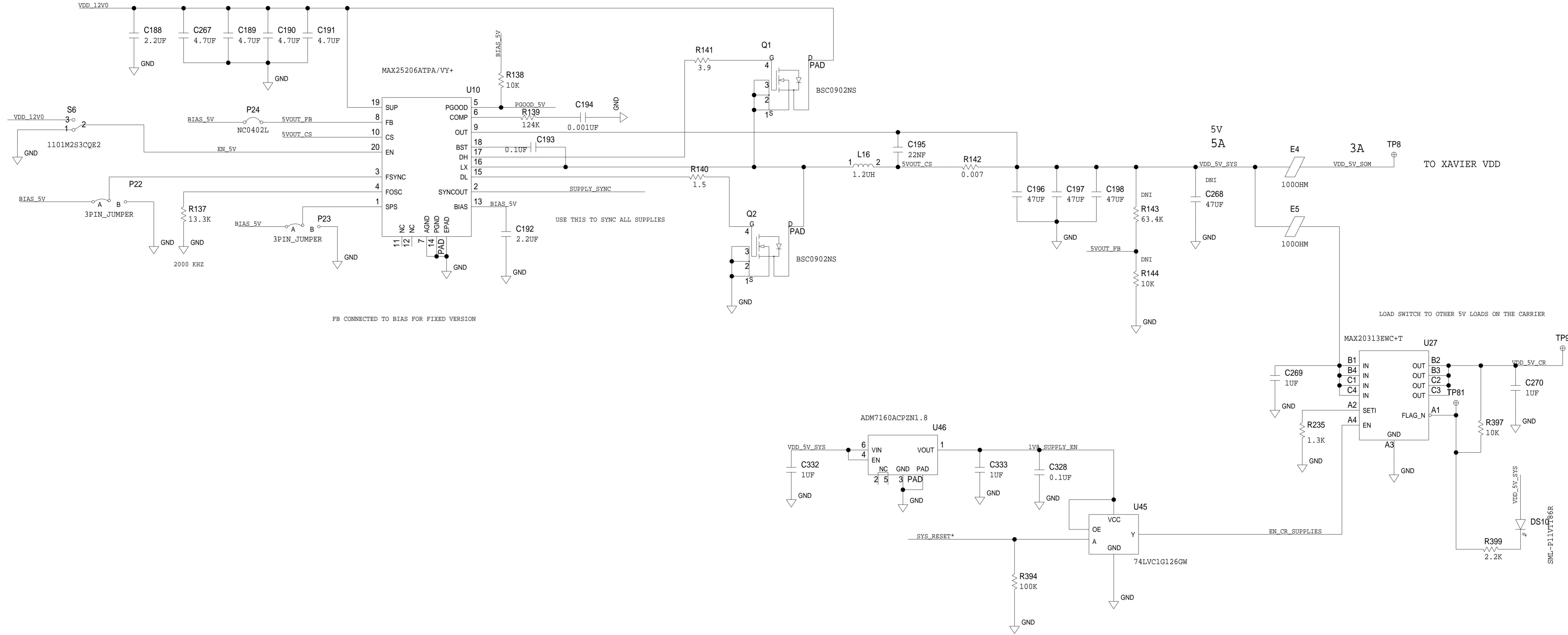

	<b>SCHEMATIC</b>		
	HW TYPE : Customer Evaluation Z Product(s): GMSL Camera : GMSL MIPI CSI-2 Deserializers		
	DESIGN VIEW <DESIGN_VIEW>	DRAWING NO. 02_074767	REV B
	PTD ENGINEER A. POP	SIZE D	SCALE 1:1
		SHEET 12 OF 17	

REVISIONS			
REV	DESCRIPTION	DATE	APPROVED

3V3 SUPPLY

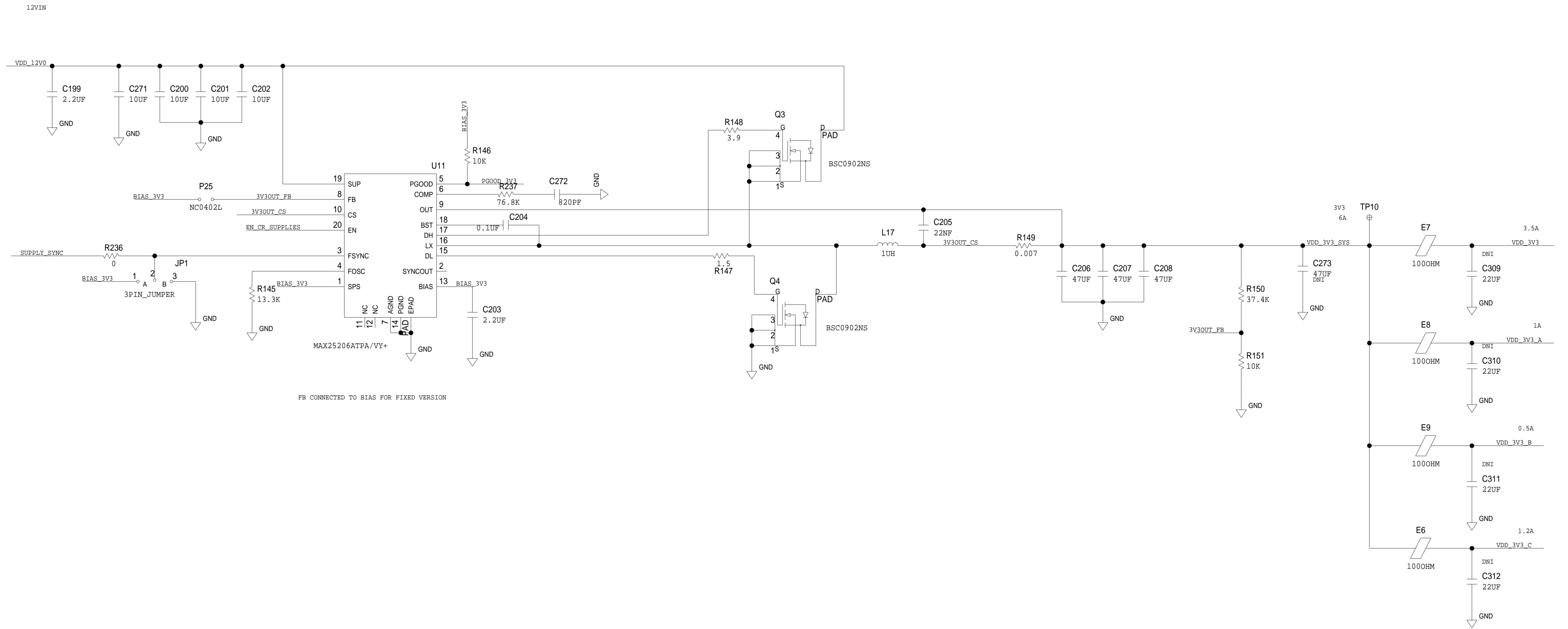

FB CONNECTED TO BIAS FOR FIXED VERSION

	<b>SCHEMATIC</b>		
	HW TYPE : Customer Evaluation Z Product(s) : GMSL Camera : GMSL MIPI CSI-2 Deserializers		
	DESIGN VIEW <DESIGN_VIEW>	DRAWING NO. 02_074767	REV B
	PTD ENGINEER A. POP	SIZE D	SCALE 1:1
		SHEET 13 OF 17	

REVISIONS			
REV	DESCRIPTION	DATE	APPROVED

# 1V0 1V2 1V8 SUPPLIES

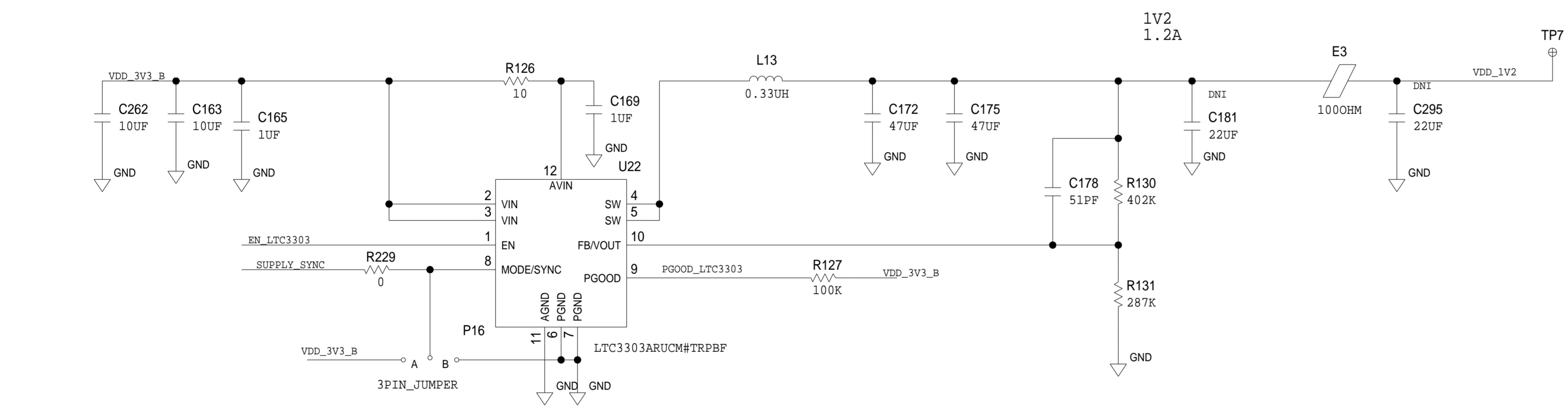
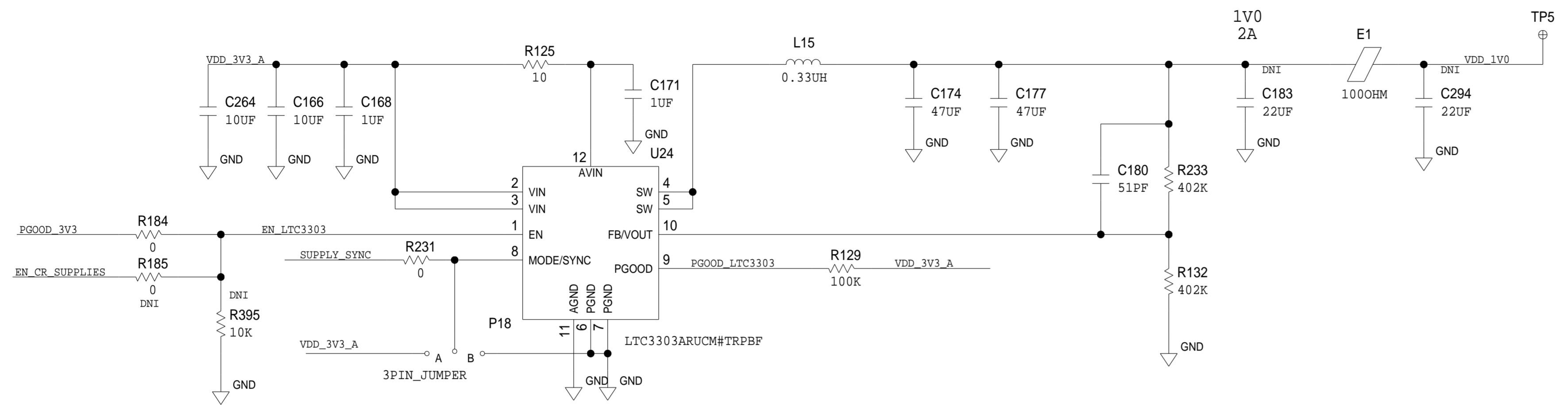

SYNC WITH MAX25206 -5V OUT

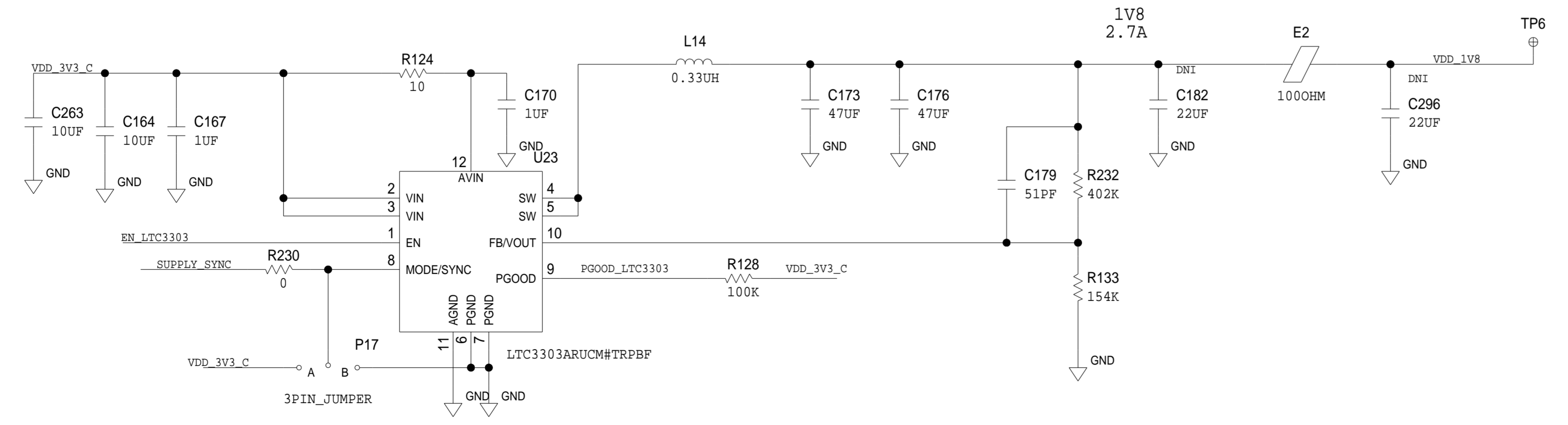

## PG LED

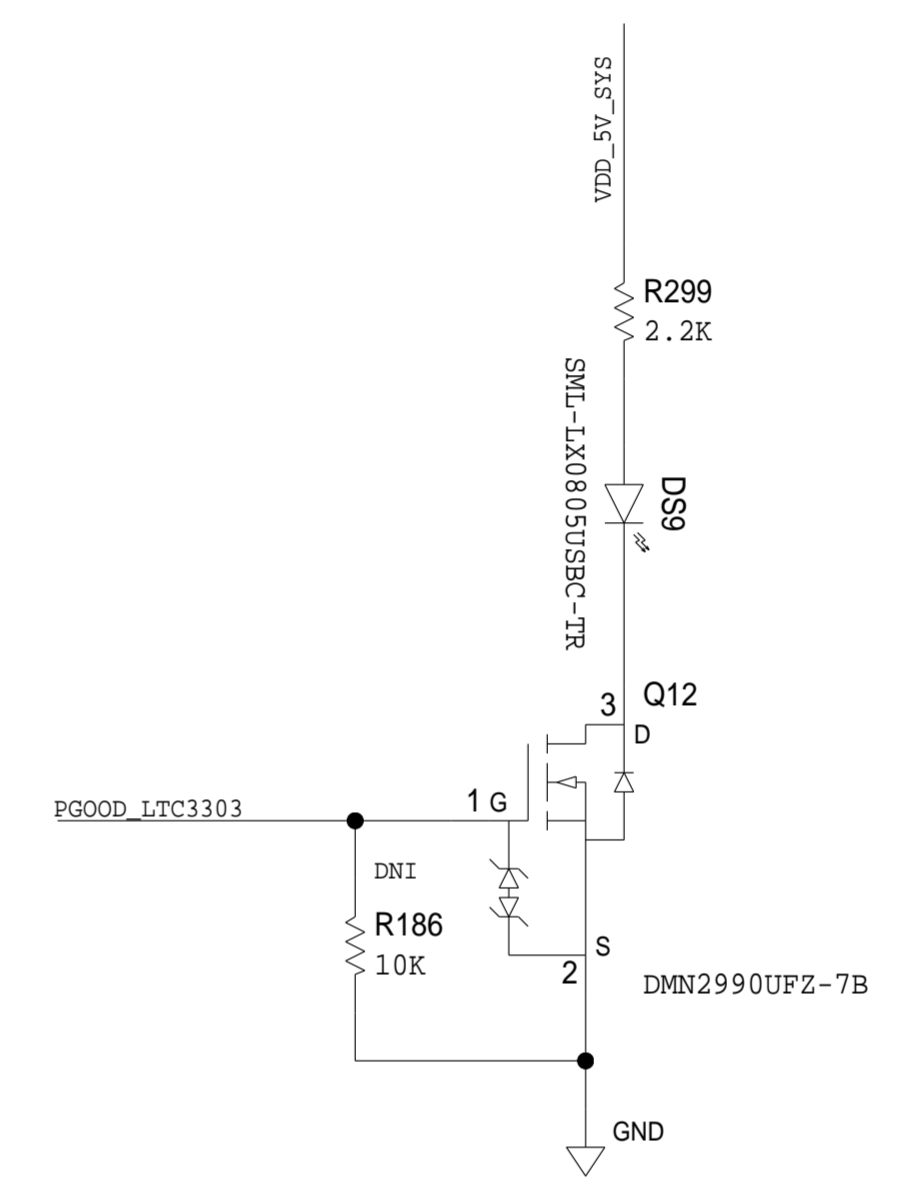

	<b>SCHEMATIC</b>		
	HW TYPE : Customer Evaluation Z Product(s) : GMSL Camera : GMSL MIPI CSI-2 Deserializers		
DESIGN VIEW <DESIGN_VIEW>	DRAWING NO. 02_074767	REV B	
PTD ENGINEER A. POP	SIZE D	SCALE 1:1	SHEET 14 OF 17